

SONLED

Inspired by the Sun,
SONLED designs light at its source.

2026

www.sonled.com

Engineered for Architecture

Inspired by nature — and especially by the balanced, natural light of the sun — SONLED develops architectural lighting systems grounded in sustainability, human-centric principles, and technical precision. The rhythm of daylight, its influence on spatial perception, and its relationship with human experience form the foundation of our design and engineering approach.

SONLED provides lighting solutions adaptable to diverse geometries and architectural scenarios. Each product is developed with controlled light distribution, measurable performance parameters, and project-oriented configurability. Geometry, proportion, material interaction, and optical discipline are considered together with technical data.

Our systems are not decorative elements; they are structural lighting components that define space. From glare-controlled optics to adjustable performance parameters and advanced control integrations, every detail is designed with clarity, balance, and engineering discipline.

Through production aligned with international compliance standards and an integrated digital technical infrastructure, SONLED delivers transparency in documentation, consistency in manufacturing, and reliability in projects. Our dynamic technical data platform and configurable product architecture provide designers and partners with measurable, accessible, and dependable project support.

For us, a lighting fixture is not an architectural accessory, but an object that enables us to see and to feel connected to natural environments.

At SONLED, light is engineered to structure space.

SONLED

Product Overview

8

LINEARS



LNR 1252

8



LNR 2640

10



LNR 2626

12



LNR 2680

14



LNR 3034

18



LNR 3339

20



LNR 3360

22



LNR 3364

24



LNR 3836

26



LNR 3838

28



LNR 3880

30



LNR 4380

32



LNR 4542

34

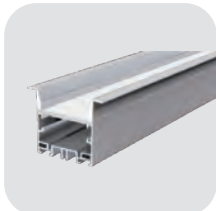

LNR 4545

36



LNR 4580

38



LNR 5070

40



LNR FLY HR 6617

42



LNR FLY HR 7030

44



LNR D60

46



LNR D85

48



LNR FLY VR

50



LNR FLY WN

52

Product Overview

ROUNDS



RRS 5050 56 RRS 8080 58 RRT 4040 60 RRT 7575 62 RRA 5060 64 RRR 2640 66



RRO 1252 68 RRO 3034 70 RCS H50 72 RCS H80 74 RCT H40 76 RCT H40 78



RCX H80 80 RCA H80 82

Product Overview

85

PANELS

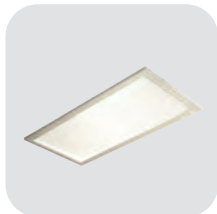

PCS H11



86 PCS H11



88 PRS H11



90 PRS H11



92 PCF H16



94 PCT H08 96

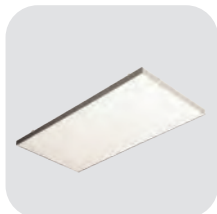

PCX H15

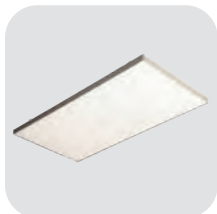

98 PLEC TX



100 PDS



102 PDA



104 PDD 106

Product Overview

CHANDELLERS

108



- Modern Acrylic Chandeliers (MAC) 110
- Modern Metal Chandeliers (MMC) 112
- Modern Felt Chandeliers (MFC) 114

SONACOUSTIQ

119



DISCOVERY

126

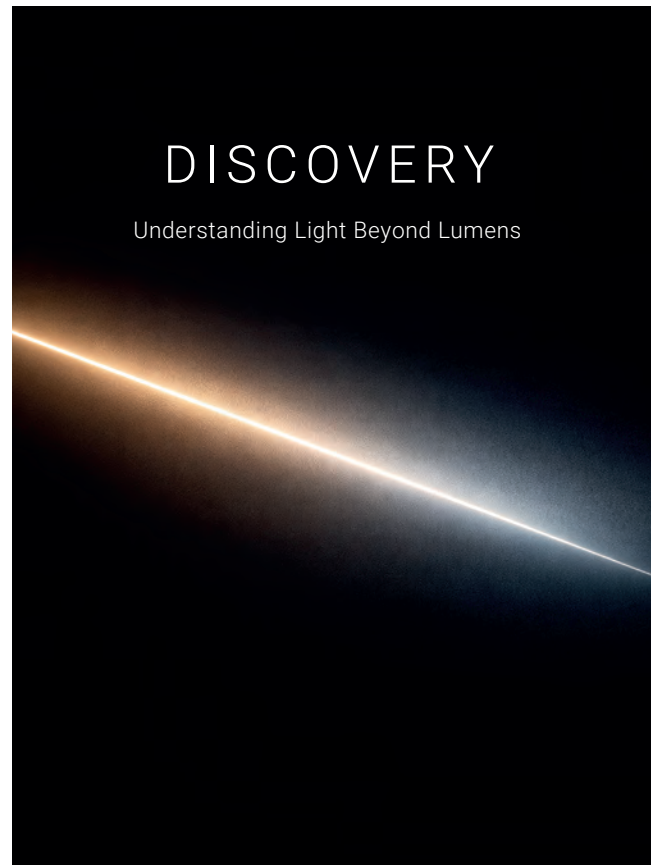





LINEARS

Structured Geometry. Controlled Light.

Linear lighting is one of the clearest ways to shape a space. It guides the eye, creates rhythm, and brings a sense of order to architecture.

Today, light is not just something we add at the end of a project. It is part of the structure itself. A single continuous line can stretch a space, highlight circulation paths, strengthen symmetry, or gently balance large volumes with calm precision.

At SONLED, our linear systems are designed to work naturally with architecture. Different profile sizes, output levels, direct or direct/indirect options, and various optic solutions make it possible to adapt each line to the needs of the project.

From refined residential interiors to large commercial spaces, our linear luminaires provide reliable performance, visual comfort, and a clean architectural presence.

Each profile is carefully designed.
Each beam is thoughtfully shaped.
Each line becomes part of the structure

LNR 1252 OL SM
Linear w12h52 Optic Lens
 Surface Mounted

LNR 1252 OL SM D2
Linear w12h52
 Surface Mounted Direct /Indirect



LNR 1252 OL SU
Linear w12h52 Optic Lens
 Suspended

LNR 1252 OL SU D2
Linear w12h52
 Suspended Direct /Indirect



Specifications

Profile Section:	w12*h52 mm
Main Body:	Aluminium Profile, static powder painted.
Optic Systems:	Optic Lens (OL)
Lighting Direction:	Direct (D1), Direct/Indirect (D2)
Installation:	Surface Mounted (SM), Suspended (SU)
Beam angle:	Narrow Beam (NB)
Light efficiency:	Avarage 100-160 lm/W
Power:	Low Power (LP), Medium Power (MP), High Power (HP)
CCT:	2400~6500K , RGB , RGBW
Control & Dimming:	On/Off, Dali, Push, Triac, 1-10V, Remote, Tunable
CRI:	Ra≥80, Ra≥90
Input voltage:	200-240V AC.

Technical Features & Certifications:

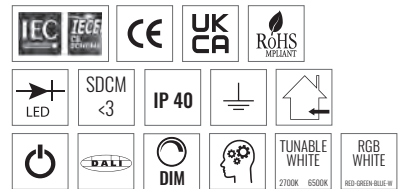

Light Beam

UGR≤11

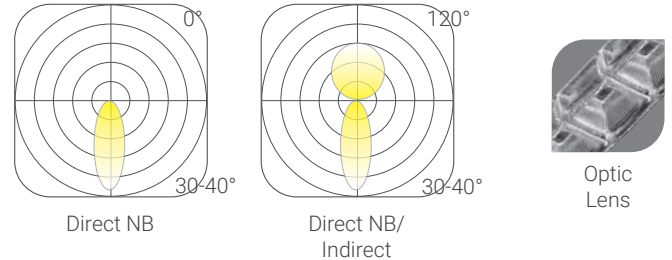

Main Body Colours:

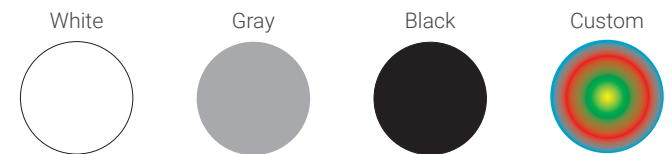

Installation

Surface Mounted



Suspended

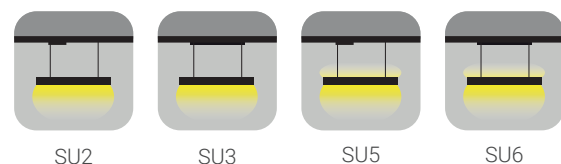

Dimensions

Sections

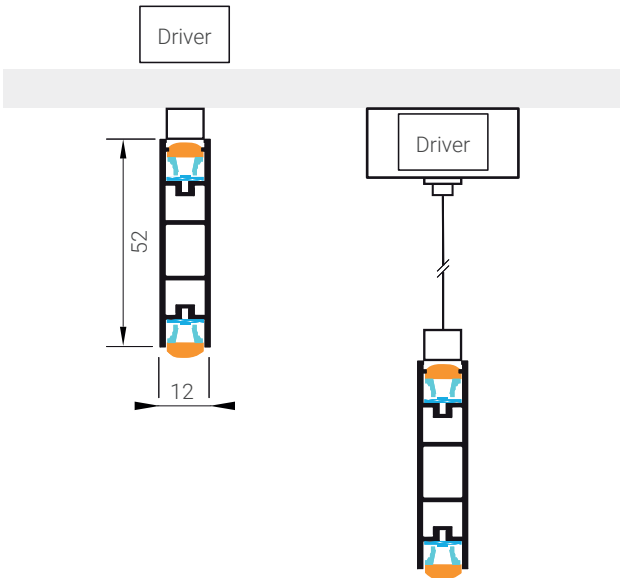

Lenght (L) mm		Power (D/I=T) W	Lumen lm	Efficiency lm/W
574	LP	8/8=16	1828	112
	MP	16/8=24	2841	116
854	LP	12/12=24	2720	112
	MP	24/12=36	4226	116
1134	LP	16/16=32	3612	112
	MP	32/16=48	5612	116
1414	LP	20/21=41	4504	112
	MP	40/21=60	6998	116

Standard Reference Conditions:

Luminous flux values are calculated at 4000K CCT with a system efficacy of 140 lm/W.

Technical values may change depending on the development of LED and equipment. For detailed and accurate lighting values, please visit our website at www.sonled.com

Custom length production is available upon request



LNR 2640 RL SM
Linear w26h40 Reflect Lens
 Surface Mounted



LNR 2640 RL SU
Linear w26h40 Reflect Lens
 Suspended



Specifications

Profile Section: w26*h40 mm
Main Body: Aluminium Profile, static powder painted.
Optic Systems: Reflect Lens (RL)
Lighting Direction: Direct (D1)
Installation: Surface Mounted (SM), Suspended (SU)
Beam angle: 24° - 36° - 48°
Light efficiency: Average 100-160 lm/W
Power: Low Power (LP), Medium Power (MP),
CCT: 2400~6500K , RGB , RGBW
Control & Dimming: On/Off, Dali, Push, Triac, 1-10V, Remote, Tunable
CRI: Ra≥80, Ra≥90
Input voltage: 200-240V AC.

Technical Features & Certifications:



Light Beam

UGR≤15

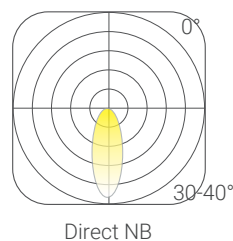

Reflect Lens

Main Body Colours:

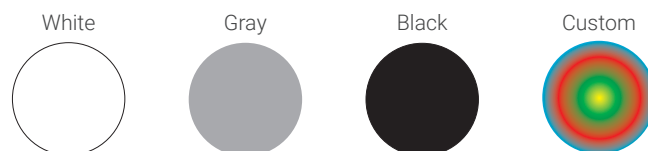

Installation

Surface Mounted



SM3

Suspended



SU2



SU3

Dimensions

Sections

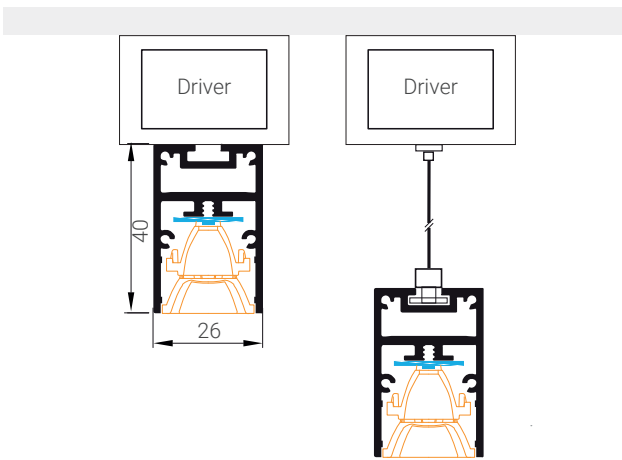

Lenght (L) mm		Power W	Lumen lm	Efficiency lm/W
574	LP	8	1117	133
	MP	17	2234	133
854	LP	13	1672	133
	MP	25	3344	133
1134	LP	17	2227	133
	MP	33	4454	133
1414	LP	21	2782	133
	MP	42	5564	133

Standard Reference Conditions:

Luminous flux values are calculated at 4000K CCT with a system efficacy of 140 lm/W.

Technical values may change depending on the development of LED and equipment. For detailed and accurate lighting values, please visit our website at www.sonled.com

Custom length production is available upon request



LNR 2626 OD
Linear w26h26 Opal Diffuser
 Recessed

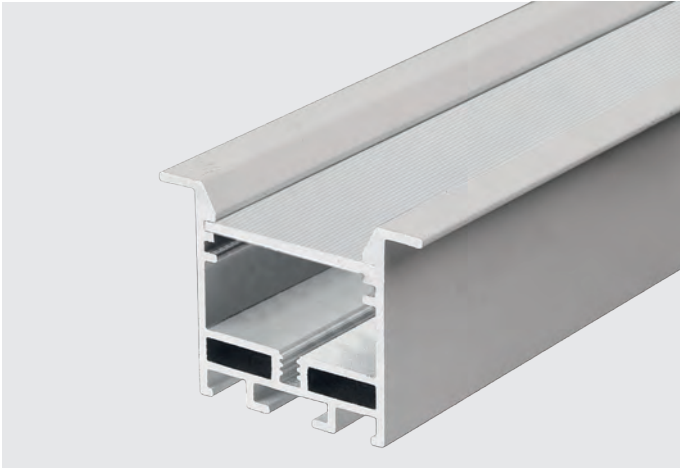

LNR 2626 PD
Linear w26h26 Prismatic Diffuser
 Recessed

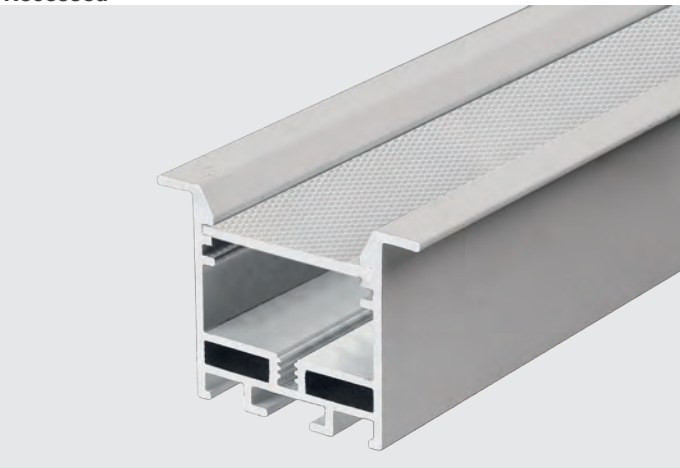

LNR 2626 RL
Linear w26h80 Reflect Lens
 Recessed

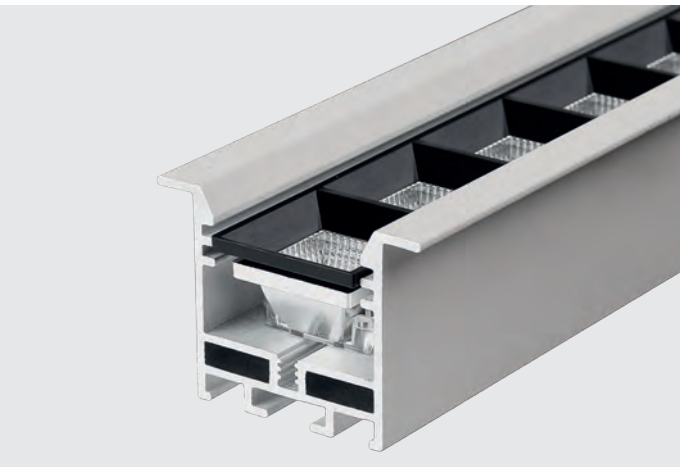

Specifications

- Profile Section:** w26-36*h26 mm
- Main Body:** Aluminium Profile, static powder painted.
- Optic Systems:** Opal Diffuser (OD), Transparent Prismatic (TP), Transparent Prismatic + Opal Film (OF), Opal + Honey Comb (OH), Opal + Grille (OG), Reflect Lens (RL)
- Lighting Direction:** Direct (D1)
- Installation:** Recessed (RC)
- Beam angle:** Wide Beam (WB), Medium Beam (MB), Narrow Beam (NB)
- Light efficiency:** Avarage 100-160 lm/W
- Power:** Low Power (LP), Medium Power (MP),
- CCT:** 2400~6500K , RGB , RGBW
- Control & Dimming:** On/Off, Dali, Push, Triac, 1-10V, Remote, Tunable
- CRI:** Ra≥80, Ra≥90
- Input voltage:** 200-240V AC.

Technical Features & Certifications:

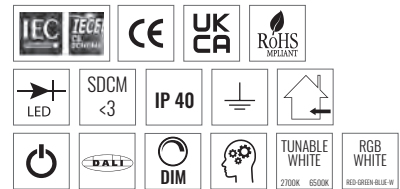

Light Beam

UGR≤19 & UGR≤20

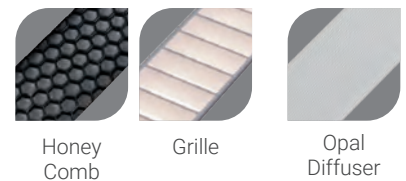
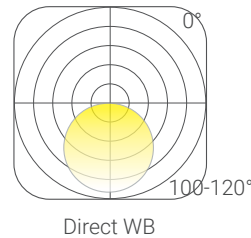

Main Body Colours:

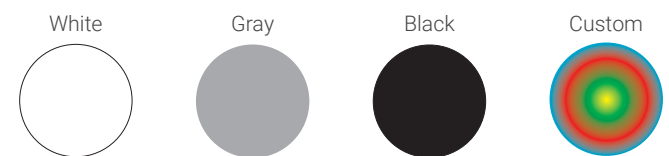

Installation

Recessed



RC

Dimensions

Sections

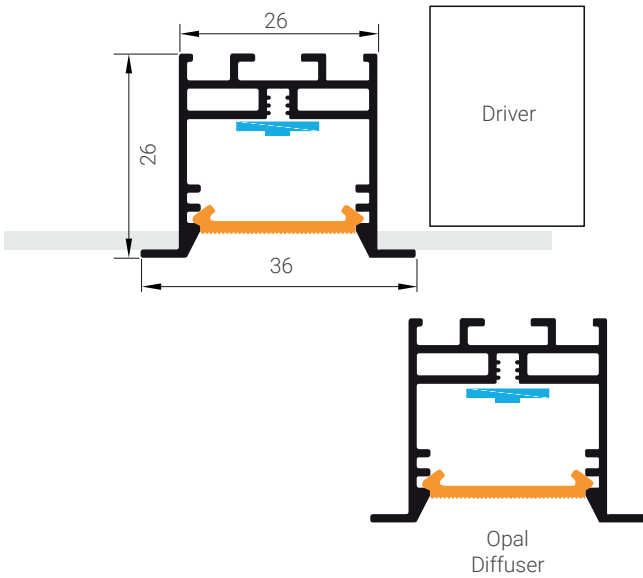

LNR 2626 with Opal Diffuser

Lenght (L) mm		Power W	Lumen lm	Efficiency lm/W
600	LP	9	853	98
	MP	13	1235	98
1000	LP	15	1421	98
	MP	21	2058	98
1200	LP	17	1705	98
	MP	25	2470	98
1500	LP	22	2132	98
	MP	32	3087	98
2000	LP	29	2842	98
	MP	42	4116	98

LNR 2626 with Prismatic Diffuser

Lenght (L) mm		Power W	Lumen lm	Efficiency lm/W
600	LP	9	1096	126
	MP	13	1588	126
1000	LP	15	1827	126
	MP	21	2646	126
1200	LP	17	2192	126
	MP	25	3175	126
1500	LP	22	2741	126
	MP	32	3969	126
2000	LP	29	3654	126
	MP	42	5292	126

UGR \leq 19



Prismatic Diffuser

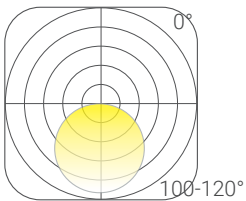

Direct WB

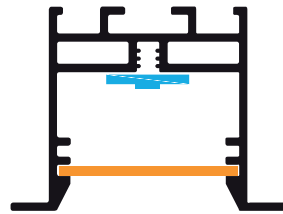

Prismatic Diffuser

UGR \leq 15



Reflect Lens

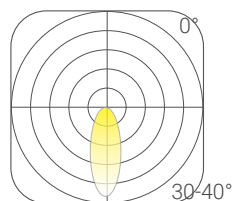

Direct NB

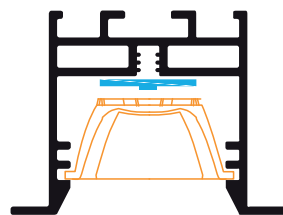

Reflect Lens

LNR 2626 with Reflect Lens

Lenght (L) mm		Power W	Lumen lm	Efficiency lm/W
600	LP	8	1117	133
	MP	17	2234	133
898	LP	13	1672	133
	MP	25	3344	133
1196	LP	17	2227	133
	MP	33	4454	133
1484	LP	21	2782	133
	MP	42	5564	133

Standard Reference Conditions:

Luminous flux values are calculated at 4000K CCT with a system efficacy of 140 lm/W. Technical values may change depending on the development of LED and equipment. For detailed and accurate lighting values, please visit our website at www.sonled.com

Custom length production is available upon request

LNR 2680 OD
Linear w26h80 Opal Diffuser
 Surface Mounted
 Suspended

LNR 2680 OD D2
Linear w26h80
 Surface Mounted
 Suspended



LNR 2680 PD
Linear w26h80 Prismatic Diffuser
 Surface Mounted
 Suspended

LNR 2680 PD D2
Linear w26h80
 Surface Mounted
 Suspended



LNR 2680 RL
Linear W26H80 Reflect Lens
 Surface Mounted
 Suspended

LNR 2680 RL D2
Linear W26H80
 Surface Mounted
 Suspended



Specifications

Profile Section: w26*h80 mm
Main Body: Aluminium Profile, static powder painted.
Optic Systems: Opal Diffuser (OD), Transparent Prismatic (TP), Transparent Prismatic + Opal Film (OF), Opal + Honey Comb (OH), Opal + Grille (OG), Reflect Lens (RL)
Lighting Direction: Direct (D1), Direct/Indirect (D2)
Installation: Surface Mounted (SM), Suspended (SU)
Beam angle: WB - Wide Beam, MB - Medium Beam, NB - Narrow Beam
Light efficiency: Avarage 100-160 lm/W
Power: Low Power (LP), Medium Power (MP),
CCT: 2400~6500K , RGB , RGBW
Control & Dimming: On/Off, Dali, Push, Triac, 1-10V, Remote, Tunable
CRI: Ra≥80, Ra≥90
Input voltage: 200-240V AC.

Technical Features & Certifications:

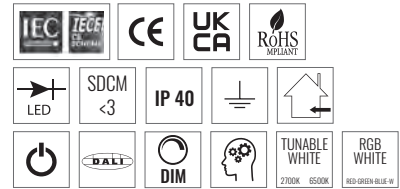

Light Beam

UGR≤19 & UGR≤20



Main Body Colours:

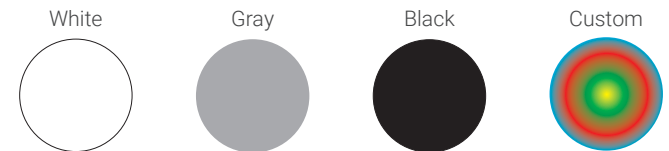

Installation

Surface Mounted

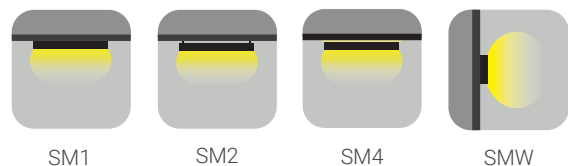

Suspended

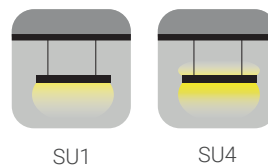

Dimensions

Sections

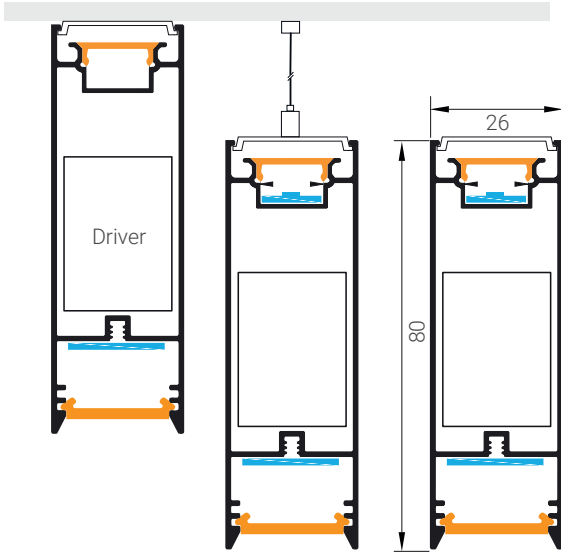

Opal Diffuser

UGR \leq 19



Prismatic Diffuser

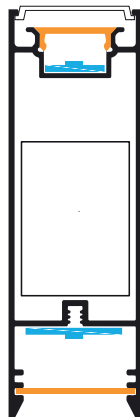
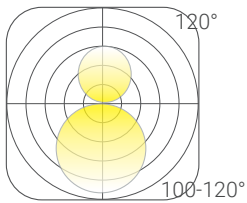

Prismatic Difuser

UGR \leq 15



Reflect Lens

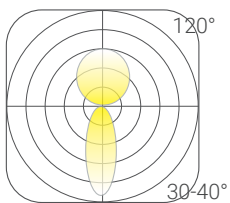

Direct NB/
Indirect

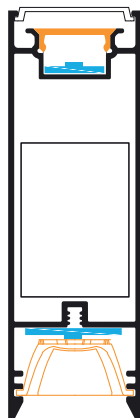

Reflect Lens

LNR 2680 with Opal Diffuser

Lenght (L) mm		Power (D/I=T) W	Lumen lm	Efficiency lm/W
600	LP	9/9=17	1705	98
	MP	13/9=21	2087	98
1000	LP	15/15=29	2842	98
	MP	21/15=36	3479	98
1200	LP	17/17=35	3410	98
	MP	25/17=43	4175	98
1500	LP	22/22=44	4363	98
	MP	32/22=53	5219	98
2000	LP	29/29=58	5680	98
	MP	42/29=71	6968	98

LNR 2680 with Prismatic Diffuser

Lenght (L) mm		Power (D/I=T) W	Lumen lm	Efficiency lm/W
600	LP	9/9=17	1949	112
	MP	13/9=21	2440	115
1000	LP	15/15=29	3248	112
	MP	21/15=36	4067	115
1200	LP	17/17=35	3898	112
	MP	25/17=43	4880	115
1500	LP	22/22=44	4872	112
	MP	32/22=53	6101	115
2000	LP	29/29=58	6496	112
	MP	42/29=71	8134	115

LNR 2680 with Reflect Lens

Lenght (L) mm		Power (D/I=T) W	Lumen lm	Efficiency lm/W
600	LP	8/9=17	1970	115
	MP	17/9=26	3087	121
898	LP	13/13=26	2948	115
	MP	25/13=38	4620	121
1192	LP	17/17=34	3926	115
	MP	33/17=51	6153	121
1494	LP	21/22=43	4905	115
	MP	42/22=63	7687	121

Standard Reference Conditions:

Luminous flux values are calculated at 4000K CCT with a system efficacy of 140 lm/W. Technical values may change depending on the development of LED and equipment. For detailed and accurate lighting values, please visit our website at www.sonled.com. Custom length production is available upon request.

LNR 2680



Opal Diffuser

Prismatic Diffuser

Opal Diffuser + Honey Comb

Opal Diffuser + Grille

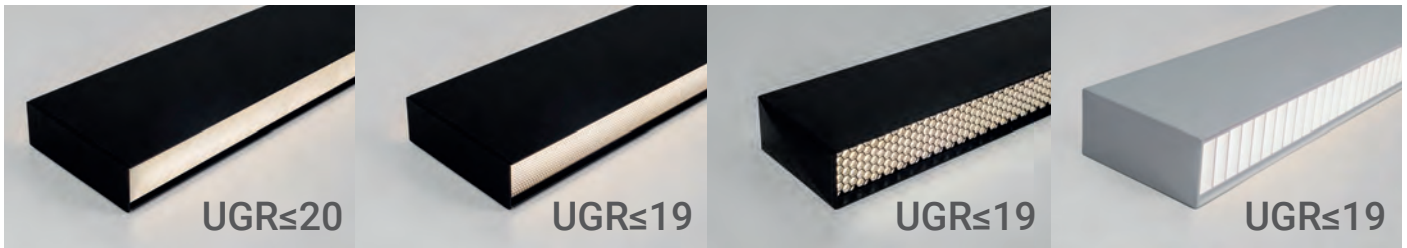

Reflect Lens Double Slot

Reflect Lens





LNR 3034 OL SM
Linear w30h34 Optic Lens
 Surface Mounted

LNR 3034 OL SM D2
Linear w30h34
 Surface Mounted Direct /Indirect



LNR 3034 OL SU
Linear w30h34 Optic Lens
 Suspended

LNR 3034 OL SU D2
Linear w30h34
 Suspended Direct /Indirect



Specifications

- Profile Section:** w30*h34 mm
- Main Body:** Aluminium Profile, static powder painted.
- Optic Systems:** Optic Lens (OL)
- Lighting Direction:** Direct (D1), Direct/Indirect (D2)
- Installation:** Surface Mounted (SM), Suspended (SU)
- Beam angle:** Narrow Beam (NB)
- Light efficiency:** Avarage 100-160 lm/W
- Power:** Low Power (LP), Medium Power (MP),
- CCT:** 2400~6500K , RGB , RGBW
- Control & Dimming:** On/Off, Dali, Push, Triac, 1-10V, Remote, Tunable
- CRI:** Ra≥80, Ra≥90
- Input voltage:** 200-240V AC.

Technical Features & Certifications:

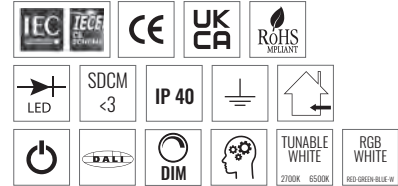

Light Beam

UGR≤15

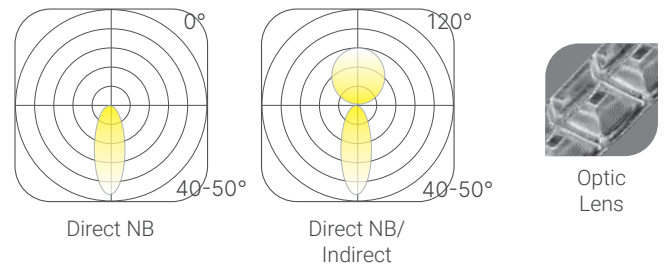

Main Body Colours:

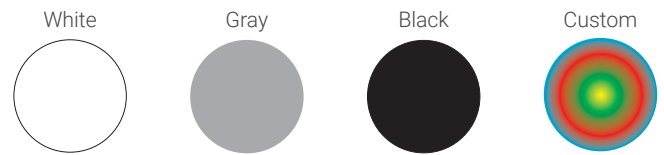

Installation

Surface Mounted



Suspended

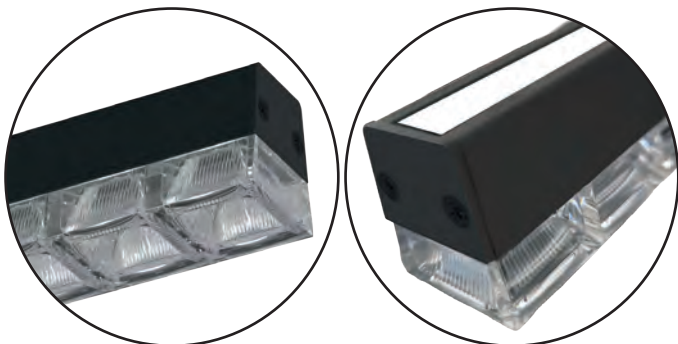
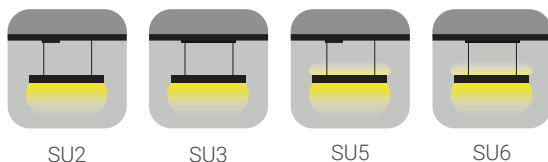

Dimensions

Sections

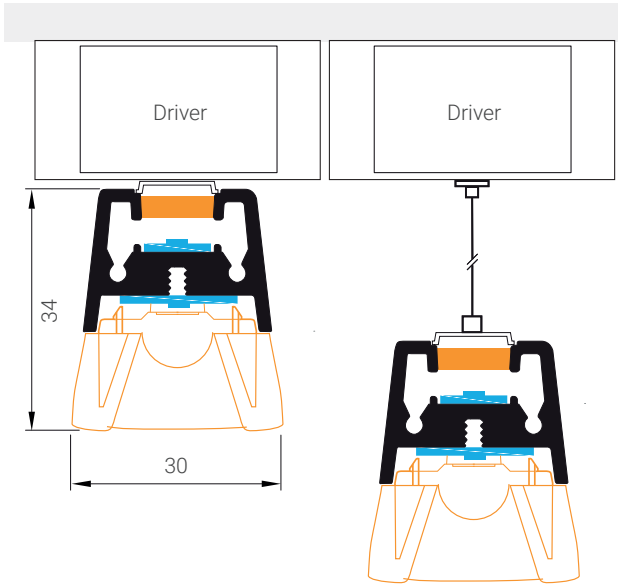

Lenght (L) mm		Power (D/I=T) W	Lumen lm	Efficiency lm/W
628	LP	9/9=18	1914	107
	MP	18/9=27	2936	110
942	LP	13/14=27	2871	107
	MP	26/14=40	4403	110
1256	LP	18/18=36	3828	107
	MP	35/18=53	5871	110
1570	LP	22/23=45	4785	107
	MP	44/23=67	7939	110

Standard Reference Conditions:

Luminous flux values are calculated at 4000K CCT with a system efficacy of 140 lm/W.

Technical values may change depending on the development of LED and equipment. For detailed and accurate lighting values, please visit our website at www.sonled.com

Custom length production is available upon request



LNR 3339 OD RC
Linear w33h39 Opal Diffuser
 Recessed

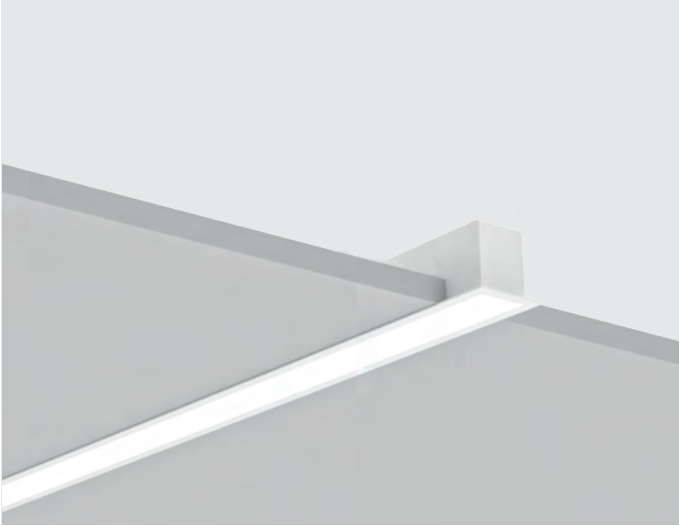

LNR 3339 OD SM
Linear w33h39 Opal Diffuser
 Surface Mounted



LNR 3339 OD SU
Linear w33h39 Opal Diffuser
 Suspended

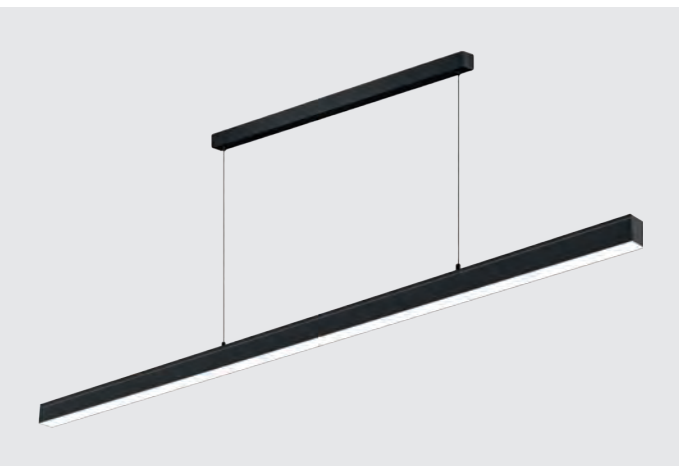

Specifications

Profile Section: w33*h39 mm,
Main Body: Aluminium Profile, static powder painted.
Optic Systems: Opal Diffuser (OD)
Lighting Direction: Direct (D1)
Installation: Recessed (RC), Surface Mounted (SM),
 Suspended (SU)
Beam angle: 120°
Light efficiency: Average 100-130 lm/W
Power: Low Power (LP), Medium Power (MP),
 High Power (HP)
CCT: 2400~6500K , RGB , RGBW
Control & Dimming: On/Off, Dali, Push, Triac, 1-10V, Remote,
 Tunable
CRI: Ra≥80, Ra≥90
Input voltage: 200-240V AC.

Technical Features & Certifications:

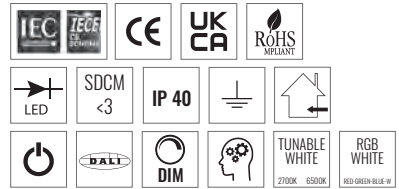

Light Beam

UGR≤20

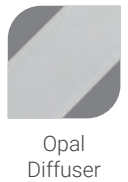
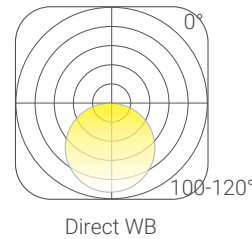

Main Body Colours:

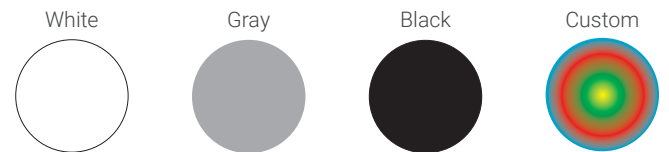

Installation

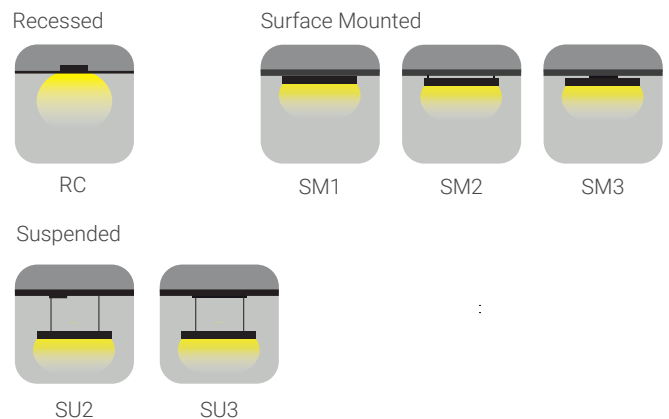

Dimensions

Sections

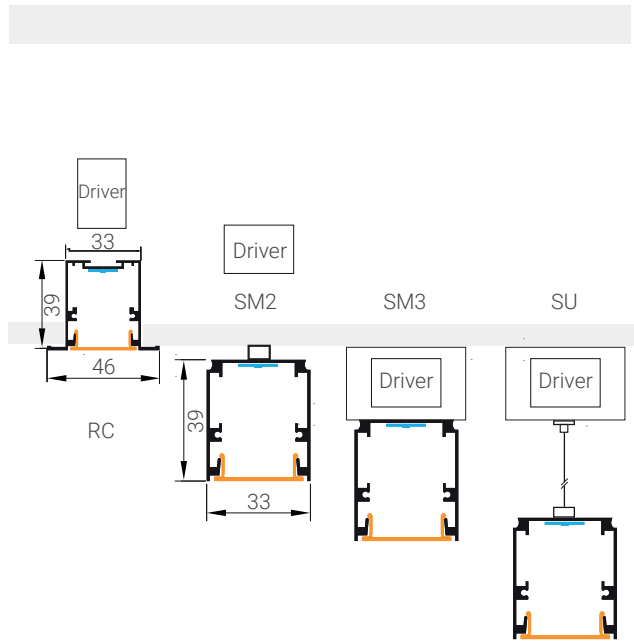

Lenght (L) mm		Power W	Lumen lm	Efficiency lm/W
600	LP	9	853	98
	MP	13	1235	98
	HP	18	1764	98
1000	LP	15	1421	98
	MP	21	2058	98
	HP	30	2940	98
1200	LP	17	1705	98
	MP	25	2470	98
	HP	36	3528	98
1500	LP	22	2132	98
	MP	32	3087	98
	HP	45	4410	98
2000	LP	29	2842	98
	MP	42	4116	98
	HP	60	5880	98

Standard Reference Conditions:

Luminous flux values are calculated at 4000K CCT with a system efficacy of 140 lm/W.
 Technical values may change depending on the development of LED and equipment. For detailed and accurate lighting values, please visit our website at www.sonled.com
 Custom length production is available upon request



LNR 3360 OD RC
Linear w33h60 Opal Diffuser
 Recessed

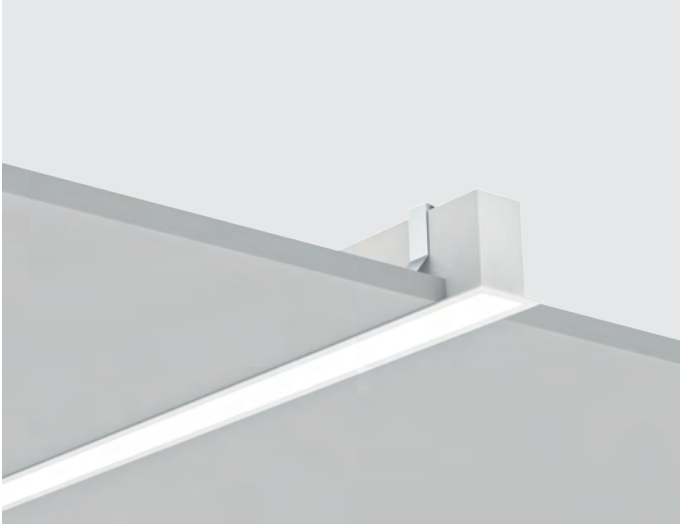

LNR 3360 OD SM
Linear w33h60 Opal Diffuser
 Surface Mounted



LNR 3360 OD SU
Linear w33h60 Opal Diffuser
 Suspended



Specifications

- Profile Section:** w33*h60 mm, w46*h60 mm
- Main Body:** Aluminium Profile, static powder painted.
- Optic Systems:** Opal Diffuser (OD)
- Lighting Direction:** Direct (D1)
- Installation:** Recessed (RC), Surface Mounted (SM)
Suspended (SU)
- Beam angle:** 120°
- Light efficiency:** Average 100-130 lm/W
- Power:** Low Power (LP), Medium Power (MP),
High Power (HP)
- CCT:** 2400~6500K, RGB, RGBW
- Control & Dimming:** On/Off, Dali, Push, Triac, 1-10V, Remote,
Tunable
- CRI:** Ra≥80, Ra≥90
- Input voltage:** 200-240V AC.

Technical Features & Certifications:

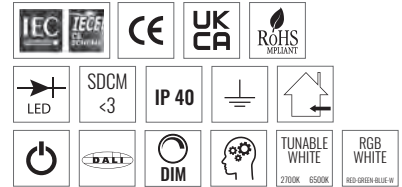

Light Beam

UGR≤20

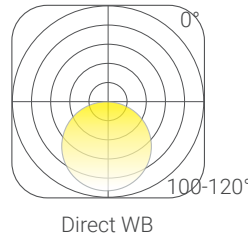

Main Body Colours:

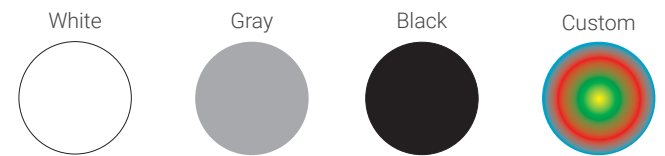

Installation

Recessed



RC

Surface Mounted



SM1

SM2

Suspended



SU1

Dimensions

Sections

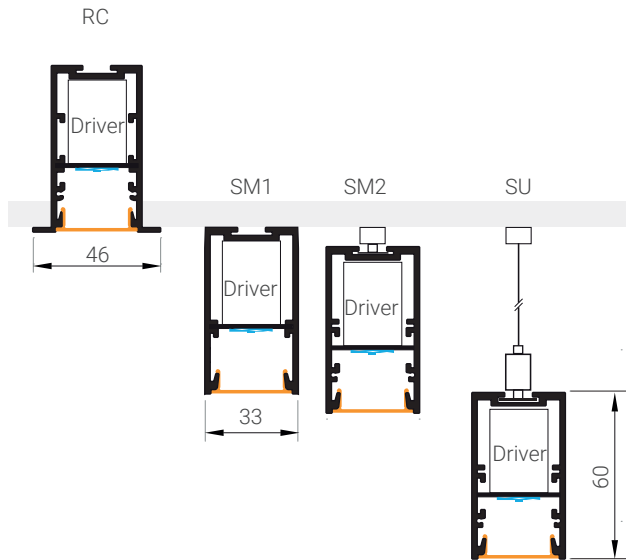

Lenght (L) mm		Power W	Lumen lm	Efficiency lm/W
600	LP	9	853	98
	MP	13	1235	98
	HP	18	1764	98
1000	LP	15	1421	98
	MP	21	2058	98
	HP	30	2940	98
1200	LP	17	1705	98
	MP	25	2470	98
	HP	36	3528	98
1500	LP	22	2132	98
	MP	32	3087	98
	HP	45	4410	98
2000	LP	29	2842	98
	MP	42	4116	98
	HP	60	5880	98

Standard Reference Conditions:

Luminous flux values are calculated at 4000K CCT with a system efficacy of 140 lm/W.
 Technical values may change depending on the development of LED and equipment. For detailed and accurate lighting values, please visit our website at www.sonled.com
 Custom length production is available upon request



LNR 3364 RL SM
Linear w33h64 Reflect Lens
 Surface Mounted



LNR 3364 RL SU
Linear w33h64 Reflect Lens
 Suspended



Specifications

Profile Section:	w33*h64 mm
Main Body:	Aluminium Profile, static powder painted.
Optic Systems:	Reflect Lens (RL)
Lighting Direction:	Direct (D1)
Installation:	Surface Mounted (SM), Suspended (SU)
Beam angle:	24° - 36° - 48°
Light efficiency:	Avarage 100-160 lm/W
Power:	Medium Power (MP), High Power (HP)
CCT:	2400~6500K , RGB , RGBW
Control & Dimming:	On/Off, Dali, Push, Triac, 1-10V, Remote, Tunable
CRI:	Ra≥80, Ra≥90
Input voltage:	200-240V AC.

Technical Features & Certifications:

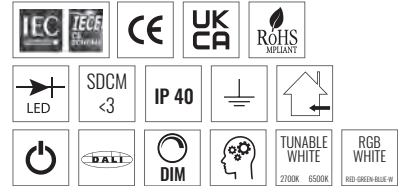

Light Beam

UGR≤15

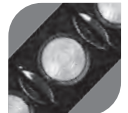
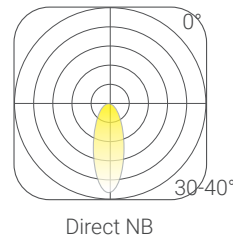

Reflect Lens

Main Body Colours:

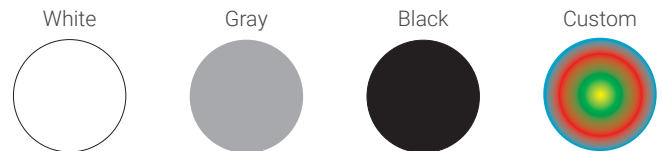

Installation

Surface Mounted



SM2

Suspended



SU1



SU2

Dimensions

Sections

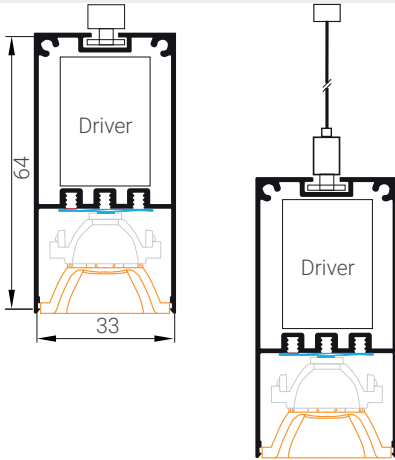

Lenght (L) mm		Power W	Lumen lm	Efficiency lm/W
664	MP	19	2473	133
	HP	25	3356	133
928	MP	26	3456	133
	HP	35	4690	133
1192	MP	33	4439	133
	HP	45	6024	133
1456	MP	41	5422	133
	HP	55	7359	133

Standard Reference Conditions:

Luminous flux values are calculated at 4000K CCT with a system efficacy of 140 lm/W.

Technical values may change depending on the development of LED and equipment. For detailed and accurate lighting values, please visit our website at www.sonled.com

Custom length production is available upon request



LNR 3836 OD RC
Linear w38h36 Opal Diffuser
 Recessed



LNR 3836 PD RC
Linear w38h36 Prismatic Diffuser
 Recessed

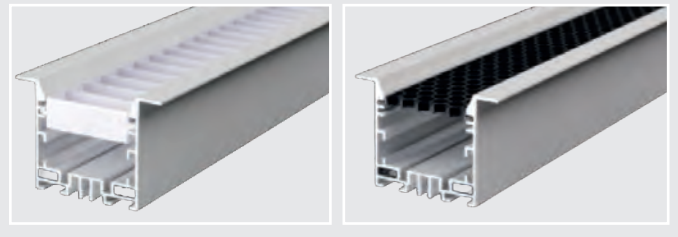
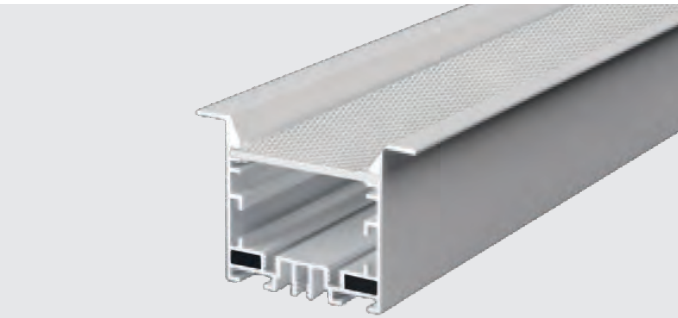

LNR 3836 RL RC
Linear w38h36 Reflect Lens
 Recessed

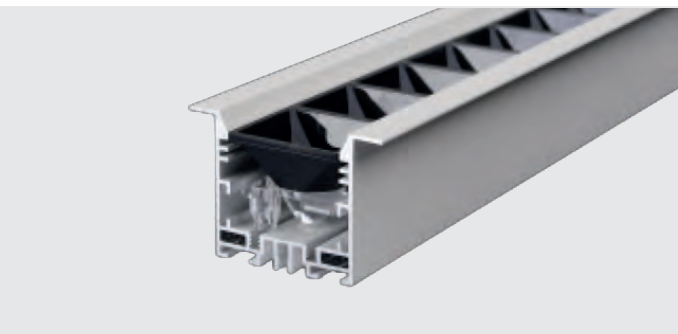

Specifications

- Profile Section:** w38-53*h36 mm
- Main Body:** Aluminium Profile, static powder painted.
- Optic Systems:** Opal Diffuser (OD), Opal Prismatic Diffuser (OP), Transparent Prismatic (TP), Transparent Prismatic + Opal Film (OF), Opal + Honey Comb (OH), Opal + Grille (OG), Reflect Lens (RL)
- Lighting Direction:** Direct (D1)
- Installation:** Recessed (RC)
- Beam angle:** Wide Beam (WB), Medium Beam (MB), Narrow Beam (NB)
- Light efficiency:** Average 100-160 lm/W
- Power:** Low Power (LP), Medium Power (MP), High Power (HP)
- CCT:** 2400~6500K, RGB, RGBW
- Control & Dimming:** On/Off, Dali, Push, Triac, 1-10V, Remote, Tunable
- CRI:** Ra≥80, Ra≥90
- Input voltage:** 200-240V AC.

Technical Features & Certifications:

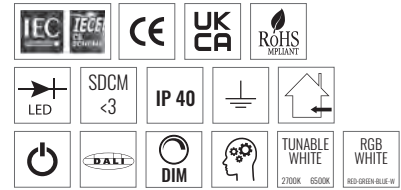

Light Beam

UGR≤17 & UGR≤20

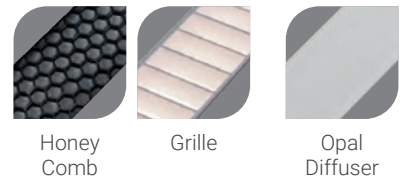
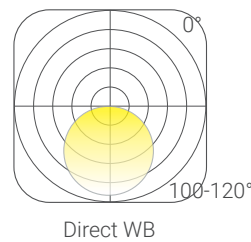

Main Body Colours:

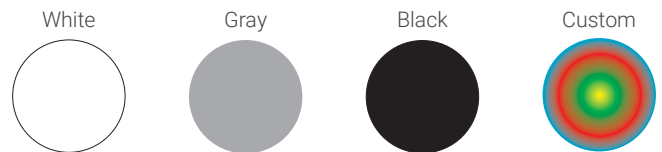

Installation

Recessed



RC

Dimensions

Sections

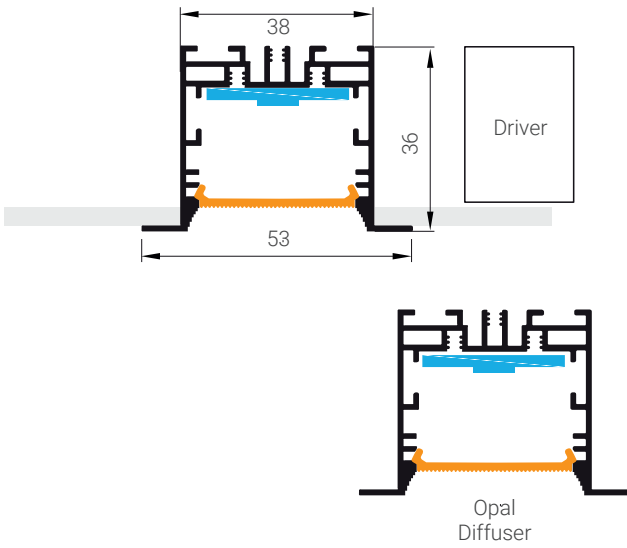

LNR 3836 with Opal Diffuser

Lenght (L) mm		Power W	Lumen lm	Efficiency lm/W
600	MP	13	1235	100
	HP	18	1764	100
1000	MP	21	2058	100
	HP	30	2940	100
1200	MP	25	2470	100
	HP	36	3528	100
1500	MP	32	3087	100
	HP	45	4410	100
2000	MP	42	4116	100
	HP	60	5880	100

UGR \leq 19



Prismatic Diffuser

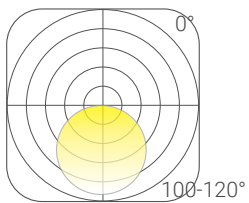

Direct WB

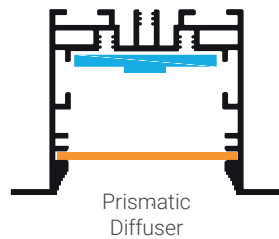

Prismatic Diffuser

LNR 3836 with Prismatic Diffuser

Lenght (L) mm		Power W	Lumen lm	Efficiency lm/W
600	MP	13	1588	126
	HP	18	2268	126
1000	MP	21	2646	126
	HP	30	3780	126
1200	MP	25	3175	126
	HP	36	4536	126
1500	MP	32	3969	126
	HP	45	5670	126
2000	MP	42	5292	126
	HP	60	7560	126

UGR \leq 15



Reflect Lens

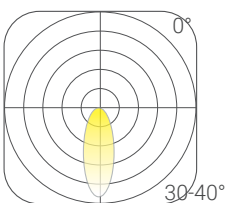

Direct NB

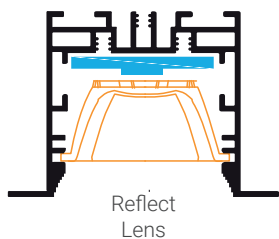

Reflect Lens

LNR 3836 with Reflect Lens

Lenght (L) mm		Power W	Lumen lm	Efficiency lm/W
664	LP	19	2473	133
	MP	25	3356	133
928	LP	26	2456	133
	MP	35	4690	133
1192	LP	33	4439	133
	MP	45	6024	133
1456	LP	41	5422	133
	MP	55	7359	133

Standard Reference Conditions:

Luminous flux values are calculated at 4000K CCT with a system efficacy of 140 lm/W. Technical values may change depending on the development of LED and equipment. For detailed and accurate lighting values, please visit our website at www.sonled.com Custom length production is available upon request

LNR 3838 OD Linear w38h38 Opal Diffuser

Surface Mounted
Suspended

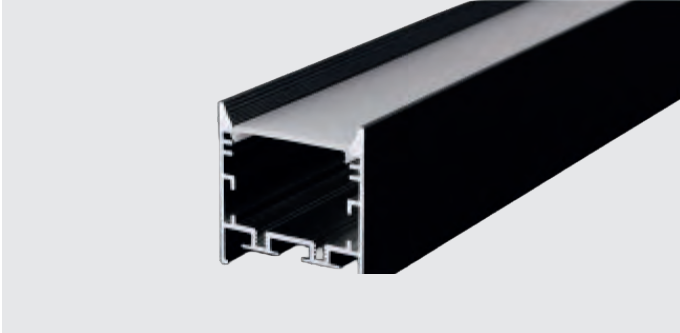

LNR 3838 PD Linear w38h38 Prismatic Diffuser

Surface Mounted
Suspended

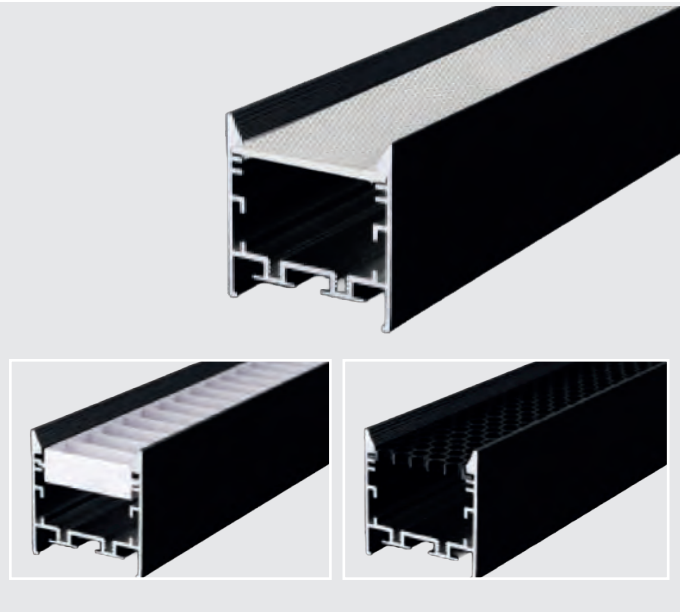

LNR 3838 RL Linear w38h38 Reflect Lens

Surface Mounted
Suspended

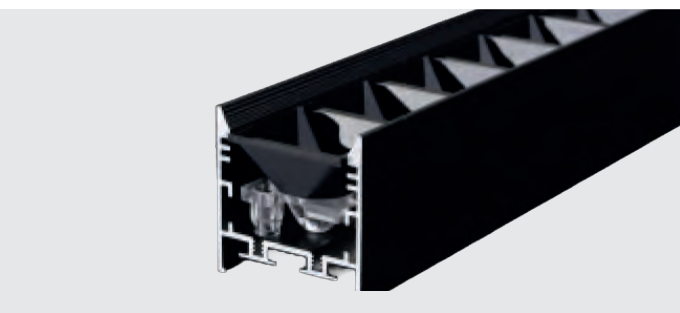

Specifications

Profile Section: w38*h38 mm
Main Body: Aluminium Profile, static powder painted.
Optic Systems: Opal Diffuser (OD), Opal Prismatic Diffuser (OP), Transparent Prismatic (TP), Transparent Prismatic + Opal Film (OF), Opal + Honey Comb (OH), Opal + Grille (OG), Reflect Lens (RL)
Lighting Direction: Direct (D1)
Installation: Surface Mounted (SM), Suspended (SU)
Beam angle: WB - Wide Beam, MB - Medium Beam, NB - Narrow Beam
Light efficiency: Average 100-160 lm/W
Power: Medium Power (MP), High Power (HP)
CCT: 2400~6500K, RGB, RGBW
Control & Dimming: On/Off, Dali, Push, Triac, 1-10V, Remote, Tunable
CRI: Ra≥80, Ra≥90
Input voltage: 200-240V AC.

Technical Features & Certifications:

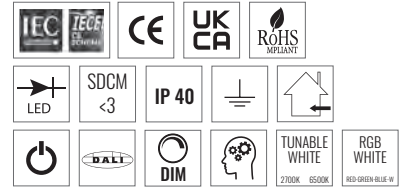

Light Beam

UGR≤19 & UGR≤20

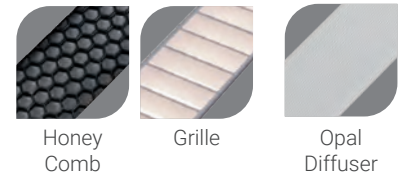
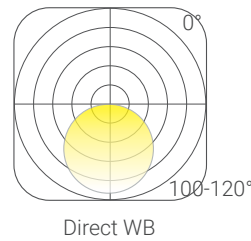

Main Body Colours:

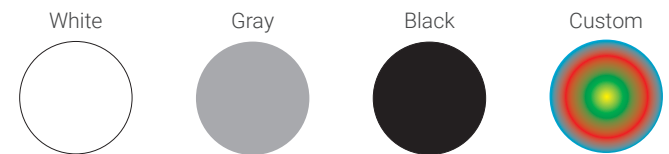

Installation

Surface Mounted

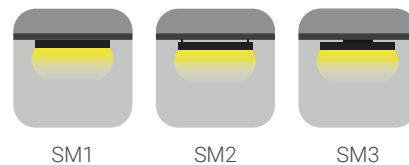

Suspended

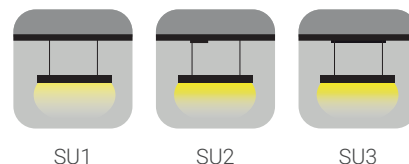

Dimensions

Sections

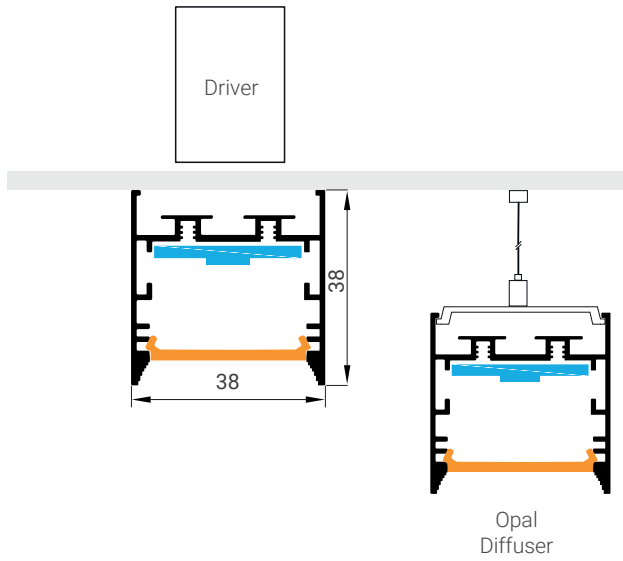

LNR 3838 with Opal Diffuser

Lenght (L) mm		Power W	Lumen lm	Efficiency lm/W
600	MP	13	1235	100
	HP	18	1764	100
1000	MP	21	2058	100
	HP	30	2940	100
1200	MP	25	2470	100
	HP	36	3528	100
1500	MP	32	3087	100
	HP	45	4410	100
2000	MP	42	4116	100
	HP	60	5880	100

UGR \leq 19



Prismatic Diffuser

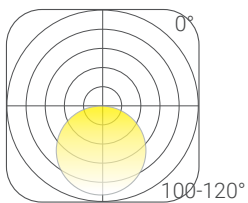

Direct WB

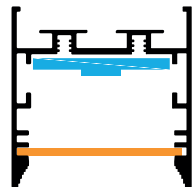

Prismatic Diffuser

LNR 3838 with Prismatic Diffuser

Lenght (L) mm		Power W	Lumen lm	Efficiency lm/W
600	MP	13	1588	126
	HP	18	2268	126
1000	MP	21	2646	126
	HP	30	3780	126
1200	MP	25	3175	126
	HP	36	4536	126
1500	MP	32	3969	126
	HP	45	5670	126
2000	MP	42	5292	126
	HP	60	7560	126

UGR \leq 15



Reflect Lens

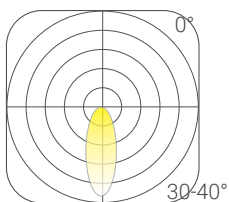

Direct NB

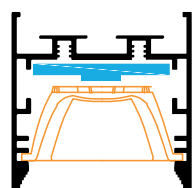

Reflect Lens

LNR 3838 with Reflect Lens

Lenght (L) mm		Power W	Lumen lm	Efficiency lm/W
664	MP	19	2473	133
	HP	25	3356	133
928	MP	26	3456	133
	HP	35	4690	133
1192	MP	33	4439	133
	HP	45	6024	133
1456	MP	41	5422	133
	HP	55	7359	133

Standard Reference Conditions:

Luminous flux values are calculated at 4000K CCT with a system efficacy of 140 lm/W. Technical values may change depending on the development of LED and equipment. For detailed and accurate lighting values, please visit our website at www.sonled.com Custom length production is available upon request

LNR 3880 OD Linear w38h80 Opal Diffuser

Surface Mounted
Suspended

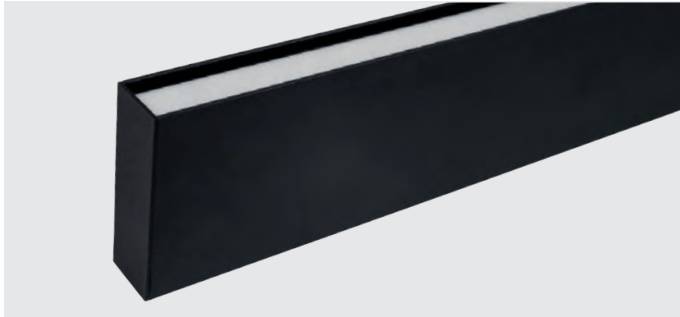

Opal Diffuser

LNR 3880 OD D2 Linear w38h80



Indirect View

UGR \leq 20



Opal Diffuser + Honey Comb

UGR \leq 19

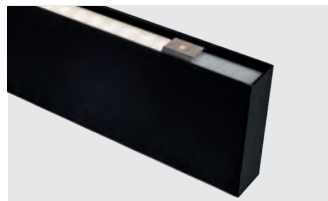

Opal Diffuser + Grille

UGR \leq 19

LNR 3880 PD Linear w38h80 Prismatic Diffuser

Surface Mounted
Suspended



Prismatic Diffuser

UGR \leq 19

LNR 3880 PD D2 Linear w38h80

LNR 3880 RL Linear w38h80 Reflect Lens

Surface Mounted
Suspended



UGR \leq 15

LNR 3880 RL D2 Linear w38h80

Specifications

Profile Section:	w38*h80 mm
Main Body:	Aluminium Profile, static powder painted.
Optic Systems:	Opal Diffuser (OD), Opal Prismatic Diffuser (OP), Transparent Prismatic (TP), Transparent Prismatic + Opal Film (OF), Opal + Honey Comb (OH), Opal + Grille (OG), Reflect Lens (RL)
Lighting Direction:	Direct (D1), Direct/Indirect (D2)
Installation:	Surface Mounted (SM), Suspended (SU)
Beam angle:	Wide Beam (WB), Medium Beam (MB), Narrow Beam (NB)
Light efficiency:	Average 100-160 lm/W
Power:	Low Power (LP), Medium Power (MP), High Power (HP)
CCT:	2400~6500K, RGB, RGBW
Control & Dimming:	On/Off, Dali, Push, Triac, 1-10V, Remote, Tunable
CRI:	Ra \geq 80, Ra \geq 90
Input voltage:	200-240V AC.

Technical Features & Certifications:

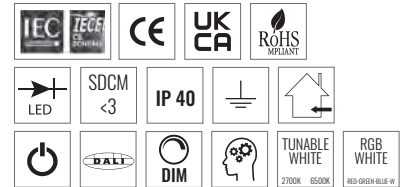

Light Beam

UGR \leq 19 & UGR \leq 20

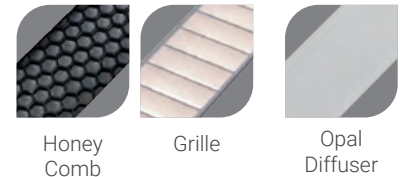
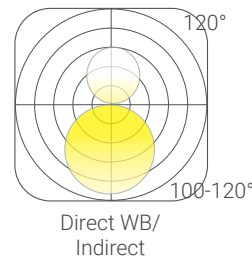

Main Body Colours:

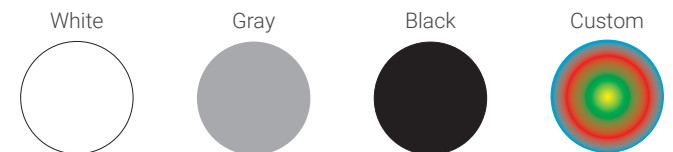

Installation

Surface Mounted



Suspended

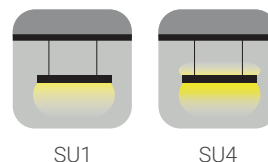

Dimensions

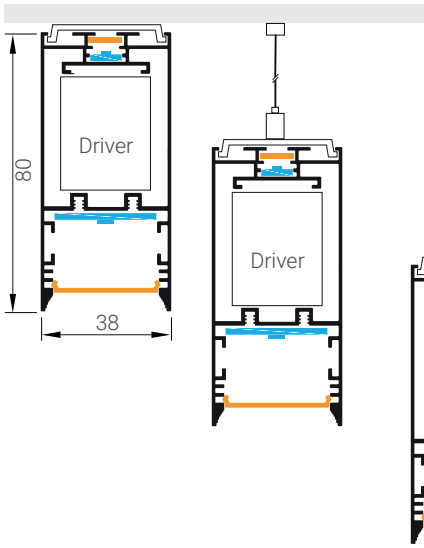

Sections

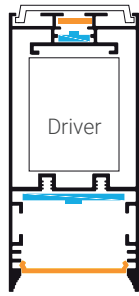

Opal Diffuser

UGR ≤ 19



Prismatic Diffuser

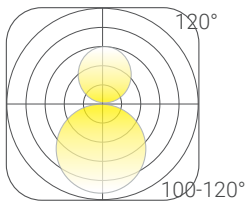

Direct NB/
Indirect

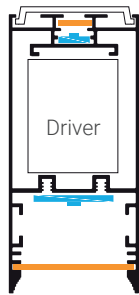

Prismatic Difuser

UGR ≤ 15



Reflect Lens

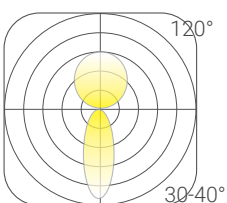

Direct NB/
Indirect

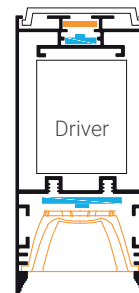

Reflect Lens

LNR 3880 with Opal Diffuser

Lenght (L) mm		Power (D/I=T) W	Lumen lm	Efficiency lm/W
600	MP	13/9=21	2087	100
	HP	18/9=27	2617	100
1000	MP	21/15=36	3419	100
	HP	30/15=45	4361	100
1200	MP	25/17=43	4175	100
	HP	36/17=53	5233	100
1500	MP	32/22=53	5219	100
	HP	45/22=67	6542	100
2000	MP	42/29=71	6958	100
	HP	60/29=89	8722	100

LNR 3880 with Prismatic Diffuser

Lenght (L) mm		Power (D/I=T) W	Lumen lm	Efficiency lm/W
600	MP	13/9=21	2440	115
	HP	18/9=27	3121	117
1000	MP	21/15=36	4067	115
	HP	30/15=45	5201	117
1200	MP	25/17=43	4880	115
	HP	36/17=53	6241	117
1500	MP	32/22=53	6101	115
	HP	45/22=67	7802	117
2000	MP	42/29=71	8134	115
	HP	60/29=89	10402	117

LNR 3880 with Reflect Lens

Lenght (L) mm		Power (D/I=T) W	Lumen lm	Efficiency lm/W
664	MP	19/10=28	3416	121
	HP	25/10=35	4299	123
928	MP	26/13=39	4775	121
	HP	35/13=49	6009	123
1192	MP	33/17=51	6133	121
	HP	45/17=63	7718	123
1456	MP	41/21=62	7491	121
	HP	55/21=76	9428	123

Standard Reference Conditions:

Luminous flux values are calculated at 4000K CCT with a system efficacy of 140 lm/W. Technical values may change depending on the development of LED and equipment. For detailed and accurate lighting values, please visit our website at www.sonled.com Custom length production is available upon request

LNR 4380 OD Linear w43h80 Opal Diffuser

Surface Mounted
Suspended



LNR 4380 OL Linear w43h80 Optic Lens

Surface Mounted
Suspended



Specifications

Profile Section:	w43*h80 mm
Main Body:	Aluminium Profile, static powder painted.
Optic Systems:	Opal Diffuser (OD), Optic Lens (OL)
Lighting Direction:	Direct (D1)
Installation:	Surface Mounted (SM), Suspended (SU)
Beam angle:	Wide Beam (WB), Medium Beam (MB), Narrow Beam (NB)
Light efficiency:	Avarage 100-160 lm/W
Power:	Low Power (LP), Medium Power (MP), High Power (HP)
CCT:	2400~6500K , RGB , RGBW
Control & Dimming:	On/Off, Dali, Push, Triac, 1-10V, Remote, Tunable
CRI:	Ra≥80, Ra≥90
Input voltage:	200-240V AC.

Technical Features
&
Certifications:

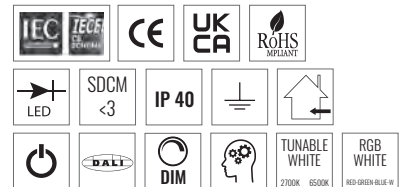

Light Beam

UGR≤20

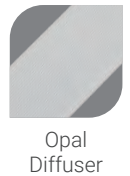
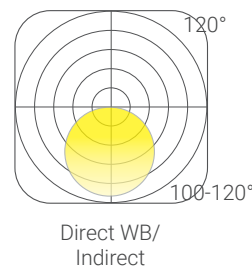

Main Body Colours:

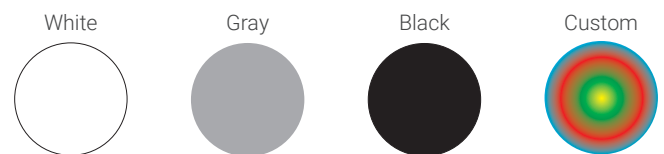

Installation

Surface Mounted

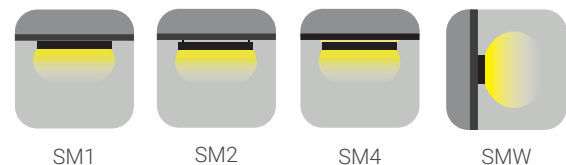

Suspended

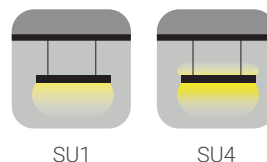

Dimensions

Sections

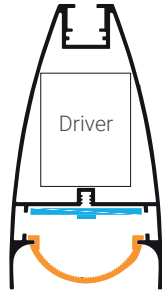
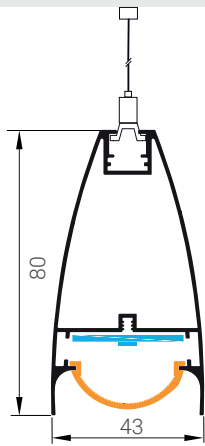

Opal Diffuser

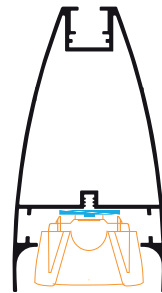

Optic Lens

UGR \leq 15

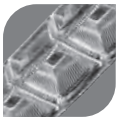

Optic Lens

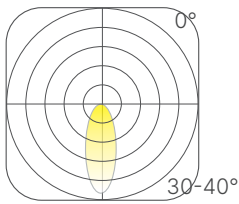

Direct NB

LNR 4380 with Opal Diffuser

Lenght (L) mm		Power W	Lumen lm	Efficiency lm/W
600	MP	13	1235	98
	HP	18	1764	98
1000	MP	21	2058	98
	HP	30	2940	98
1200	MP	25	2470	98
	HP	36	3528	98
1500	MP	32	3087	98
	HP	45	4410	98
2000	MP	42	4116	98
	HP	60	5880	98

LNR 4380 with Optic Lens

Lenght (L) mm		Power W	Lumen lm	Efficiency lm/W
628	LP	9	1022	116
	MP	18	2043	116
942	LP	13	1532	116
	MP	26	3065	116
1256	LP	18	2943	116
	MP	35	4087	116
1570	LP	22	2554	116
	MP	44	5108	116

Standard Reference Conditions:

Luminous flux values are calculated at 4000K CCT with a system efficacy of 140 lm/W.

Technical values may change depending on the development of LED and equipment. For detailed and accurate lighting values, please visit our website at www.sonled.com

Custom length production is available upon request



LNR 4542 OD SM
Linear w45h42 Opal Diffuser
 Surface Mounted

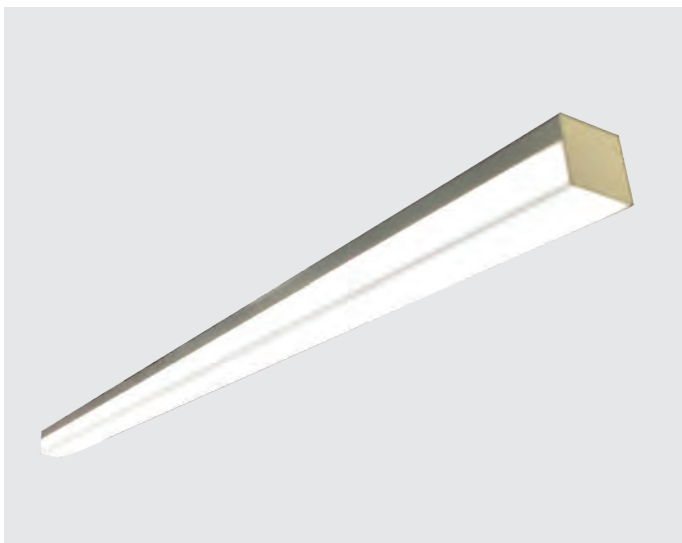

Specifications

- Profile Section:** w45*h42 mm,
- Main Body:** Aluminium Profile, static powder painted.
- Optic Systems:** Opal Diffuser (OD)
- Lighting Direction:** Direct (D1)
- Installation:** Surface Mounted (SM), Suspended (SU)
- Beam angle:** 150°
- Light efficiency:** Average 100-130 lm/W
- Power:** Medium Power (MP), High Power (HP)
- CCT:** 2400~6500K , RGB , RGBW
- Control & Dimming:** On/Off, Dali, Push, Triac, 1-10V, Remote, Tunable
- CRI:** Ra≥80, Ra≥90
- Input voltage:** 200-240V AC.

Technical Features & Certifications:



LNR 4542 OD SU
Linear w45h42 Opal Diffuser
 Suspended

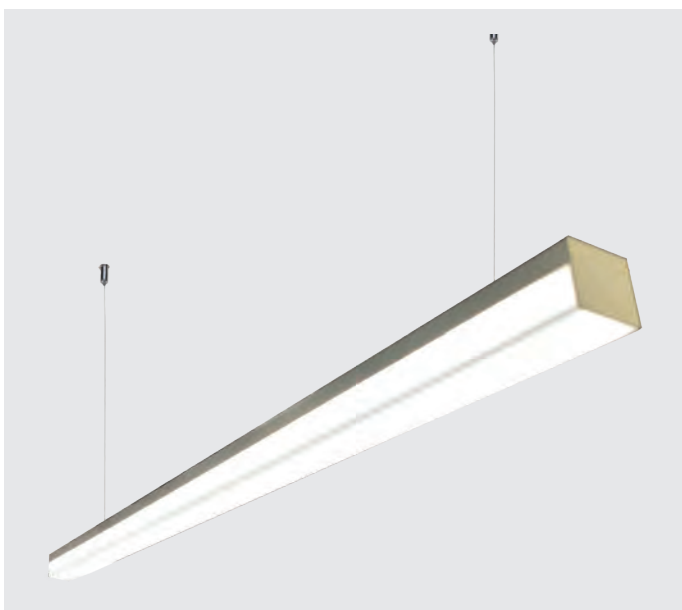

Light Beam

UGR≤20

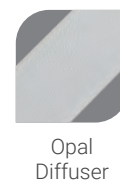
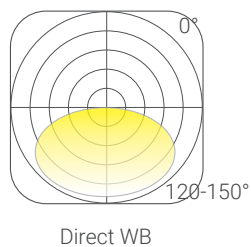

Main Body Colours:

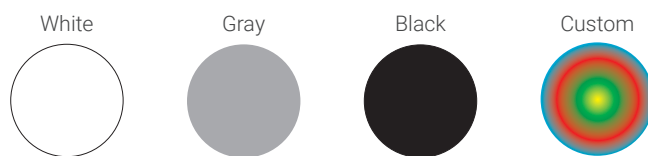

Installation

Surface Mounted

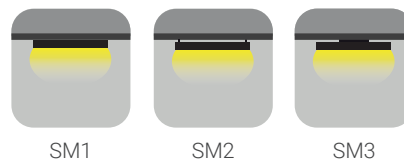

Suspended

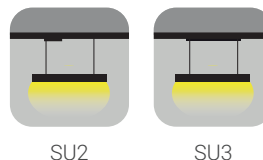

Dimensions

Sections

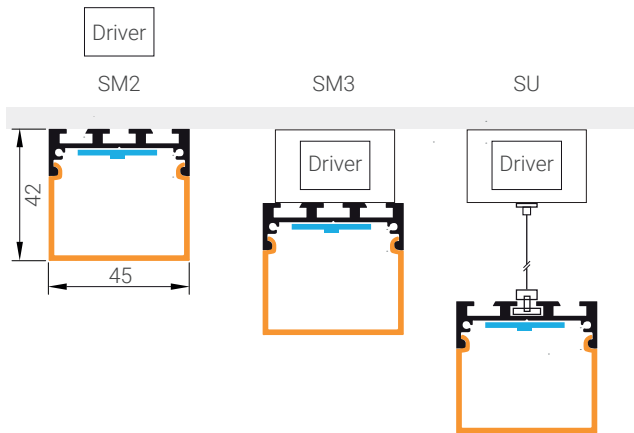

Lenght (L) mm		Power W	Lumen lm	Efficiency lm/W
600	MP	13	1235	98
	HP	18	1764	98
1000	MP	21	2058	98
	HP	30	2940	98
1200	MP	25	2470	98
	HP	36	3528	98
1500	MP	32	3087	98
	HP	45	4410	98
2000	MP	42	4116	98
	HP	60	5880	98

Standard Reference Conditions:

Luminous flux values are calculated at 4000K CCT with a system efficacy of 140 lm/W. Technical values may change depending on the development of LED and equipment. For detailed and accurate lighting values, please visit our website at www.sonled.com Custom length production is available upon request



LNR 4545 OD RC Linear w45h45 Opal Diffuser

Recessed



LNR 4545 PD RC Linear w45h45 Prismatic Diffuser

Recessed

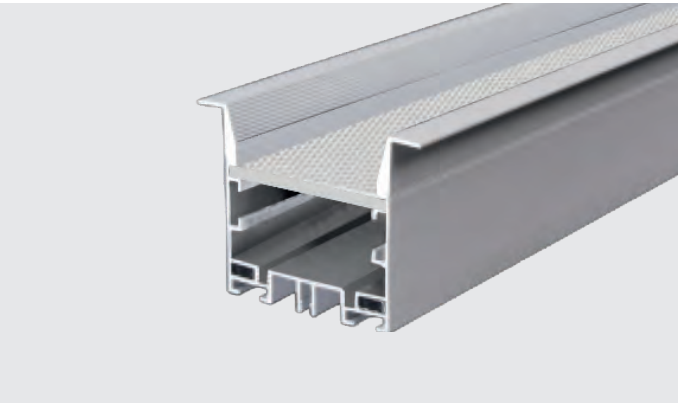

LNR 4545 RL RC Linear w45h45 Reflect Lens

Recessed



Specifications

- Profile Section:** w45-60*h45 mm
- Main Body:** Aluminium Profile, static powder painted.
- Optic Systems:** Opal Diffuser (OD), Opal Prismatic Diffuser (OP), Transparent Prismatic (TP), Transparent Prismatic + Opal Film (OF), Opal + Honey Comb (OH), Opal + Grille (OG), Reflect Lens (RL)
- Lighting Direction:** Direct (D1)
- Installation:** Recessed (RC)
- Beam angle:** Wide Beam (WB), Medium Beam (MB), Narrow Beam (NB)
- Light efficiency:** Average 100-160 lm/W
- Power:** Medium Power (MP), High Power (HP)
- CCT:** 2400~6500K, RGB, RGBW
- Control & Dimming:** On/Off, Dali, Push, Triac, 1-10V, Remote, Tunable
- CRI:** Ra≥80, Ra≥90
- Input voltage:** 200-240V AC.

Technical Features & Certifications:

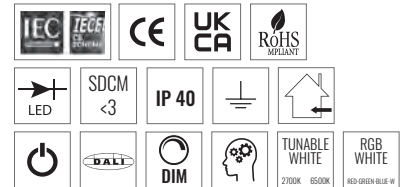

Light Beam

UGR≤19 & UGR≤20

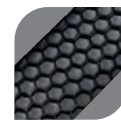
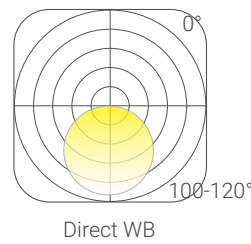

Honey Comb

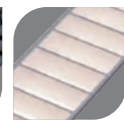

Grille



Opal Diffuser

Main Body Colours:

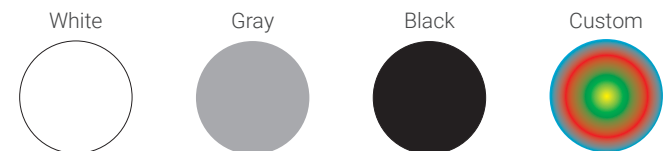

Installation

Recessed



RC

Dimensions

Sections

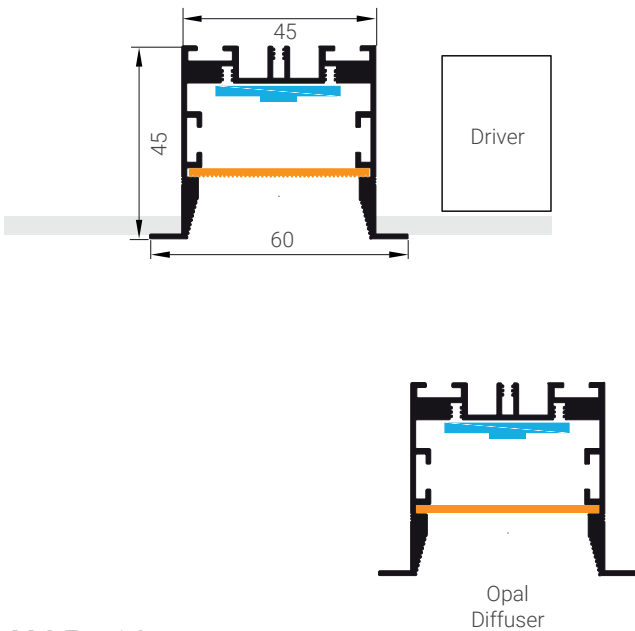

LNR 4545 with Opal Diffuser

Lenght (L) mm		Power W	Lumen lm	Efficiency lm/W
600	MP	13	1235	100
	HP	18	1764	100
1000	MP	21	2058	100
	HP	30	2940	100
1200	MP	25	2470	100
	HP	36	3528	100
1500	MP	32	3087	100
	HP	45	4410	100
2000	MP	42	4116	100
	HP	60	5880	100

UGR \leq 19



Prismatic Diffuser

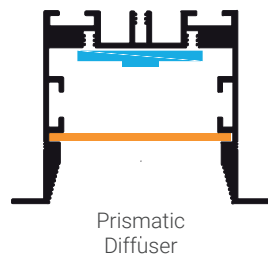
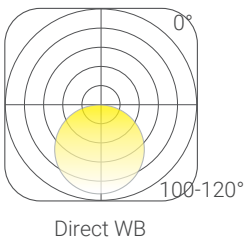

Prismatic Diffuser

LNR 4545 with Prismatic Diffuser

Lenght (L) mm		Power W	Lumen lm	Efficiency lm/W
600	MP	13	1588	126
	HP	18	2268	126
1000	MP	21	2646	126
	HP	30	3780	126
1200	MP	25	3175	126
	HP	36	4536	126
1500	MP	32	3969	126
	HP	45	5670	126
2000	MP	42	5292	126
	HP	60	7560	126

UGR \leq 15



Reflect Lens

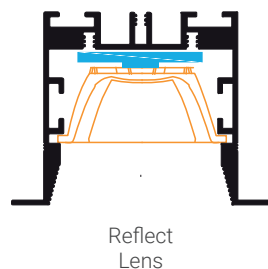
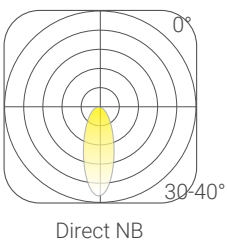

Reflect Lens

LNR 4545 with Reflect Lens

Lenght (L) mm		Power W	Lumen lm	Efficiency lm/W
690	MP	19	2570	133
	HP	26	3487	133
918	MP	26	3419	133
	HP	35	4640	133
1146	MP	32	4268	133
	HP	44	5792	133
1602	MP	45	5966	133
	HP	61	8097	133

Standard Reference Conditions:

Luminous flux values are calculated at 4000K CCT with a system efficacy of 140 lm/W. Technical values may change depending on the development of LED and equipment. For detailed and accurate lighting values, please visit our website at www.sonled.com Custom length production is available upon request

LNR 4580 OP
Linear w45h80 Opal Diffuser

Surface Mounted
Suspended



LNR 4580 OP D2
Linear w45h80

Surface Mounted
Suspended

LNR 4580 PD
Linear w45h80 Prismatic Diffuser

Surface Mounted
Suspended



LNR 4580 PD D2
Linear w45h80

Surface Mounted
Suspended

LNR 4580 RL
Linear w45h80 Reflect Lens

Surface Mounted
Suspended



LNR 4580 RL D2
Linear w45h80

Surface Mounted
Suspended

Specifications

- Profile Section:** w45*h80 mm
Main Body: Aluminium Profile, static powder painted.
Optic Systems: Opal Diffuser (OD), Opal Prismatic Diffuser (OP), Transparent Prismatic (TP), Transparent Prismatic + Opal Film (OF), Opal + Honey Comb (OH), Opal + Grille (OG), Reflect Lens (RL)
Lighting Direction: Direct (D1), Direct/Indirect (D2)
Installation: Surface Mounted (SM), Suspended (SU)
Beam angle: Wide Beam (WB), Medium Beam (MB), Narrow Beam (NB)
Light efficiency: Average 100-160 lm/W
Power: Medium Power (MP), High Power (HP)
CCT: 2400~6500K, RGB, RGBW
Control & Dimming: On/Off, Dali, Push, Triac, 1-10V, Remote, Tunable
CRI: Ra≥80, Ra≥90
Input voltage: 200-240V AC.

Technical Features & Certifications:

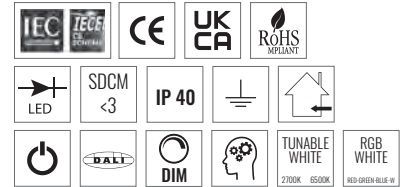

Light Beam

UGR≤19 & UGR≤20



Main Body Colours:

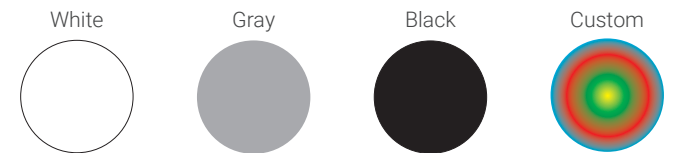

Installation

Surface Mounted

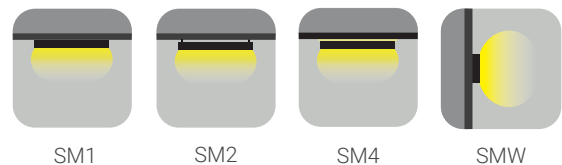

Suspended

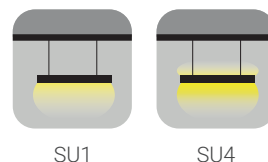

Dimensions

Sections

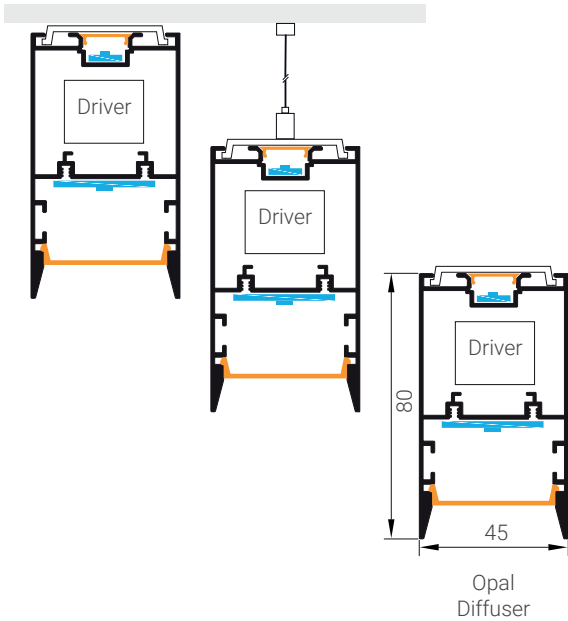

LNR 4580 with Opal Diffuser

Lenght (L) mm		Power (D/I=T) W	Lumen lm	Efficiency lm/W
600	MP	13/9=21	2087	100
	HP	18/9=27	2617	100
1000	MP	21/15=36	3479	100
	HP	30/15=45	4361	100
1200	MP	25/17=43	4175	100
	HP	36/17=53	5233	100
1500	MP	32/22=53	5219	100
	HP	45/22=67	6542	100
2000	MP	42/29=71	6958	100
	HP	60/29=89	8722	100

UGR_{≤19}



Prismatic Diffuser

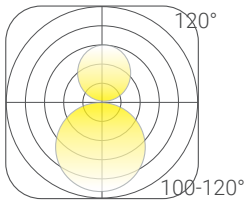

Direct NB/
Indirect

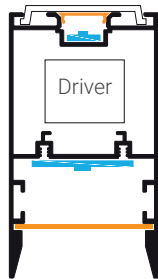

Prismatic Difuser

LNR 4580 with Micro Prismatic Diffuser

Lenght (L) mm		Power (D/I=T) W	Lumen lm	Efficiency lm/W
600	MP	13/9=21	2440	115
	HP	18/9=27	3121	117
1000	MP	21/15=36	4067	115
	HP	30/15=45	5201	117
1200	MP	25/17=43	4880	115
	HP	36/17=53	6241	117
1500	MP	32/22=53	6101	115
	HP	45/22=67	7802	117
2000	MP	42/29=71	8134	115
	HP	60/29=89	10402	117

UGR_{≤15}



Reflect Lens

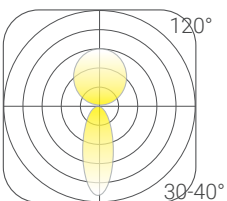

Direct NB/
Indirect

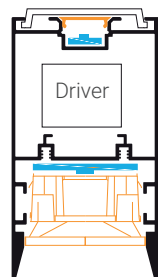

Reflect Lens

LNR 4580 with Reflect Lens

Lenght (L) mm		Power (D/I=T) W	Lumen lm	Efficiency lm/W
690	MP	19/10=29	3550	121
	HP	26/10=36	4468	123
918	MP	26/13=39	4723	121
	HP	35/13=48	5944	123
1146	MP	32/17=49	5896	121
	HP	44/17=60	7420	123
1602	MP	45/23=68	8242	121
	HP	61/23=84	10373	123

Standard Reference Conditions:

Luminous flux values are calculated at 4000K CCT with a system efficacy of 140 lm/W. Technical values may change depending on the development of LED and equipment. For detailed and accurate lighting values, please visit our website at www.sonled.com Custom length production is available upon request

LNR 5070 OD SM
Linear w50h70 Opal Diffuser
 Surface Mounted



LNR 5070 OD SU
Linear w50h70 Opal Diffuser
 Suspended



Specifications

- Profile Section:** w50*h70 mm,
- Main Body:** Aluminium Profile, static powder painted.
- Optic Systems:** Opal Diffuser (OD)
- Lighting Direction:** Direct (D1)
- Installation:** Surface Mounted (SM), Suspended (SU)
- Beam angle:** 120°
- Light efficiency:** Average 100-130 lm/W
- Power:** Medium Power (MP), High Power (HP)
- CCT:** 2400~6500K , RGB , RGBW
- Control & Dimming:** On/Off, Dali, Push, Triac, 1-10V, Remote, Tunable
- CRI:** Ra≥80, Ra≥90
- Input voltage:** 200-240V AC.

Technical Features & Certifications:

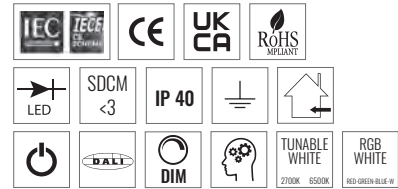

Light Beam

UGR≤20

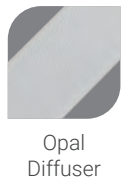
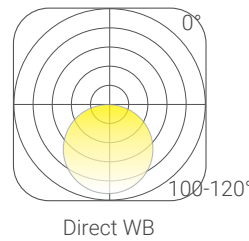

Main Body Colours:

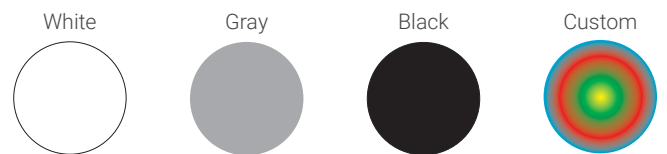

Installation

Surface Mounted

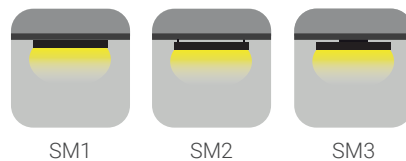

Suspended

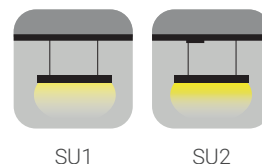

Dimensions

Sections

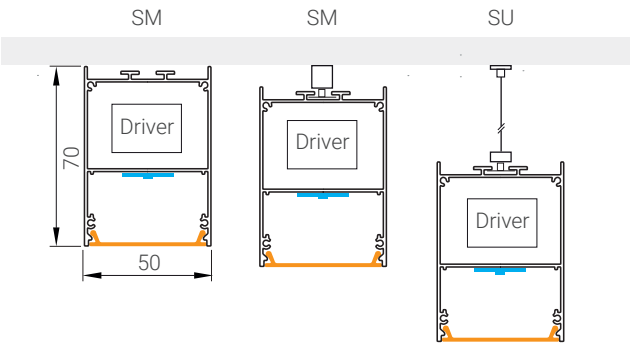

LNR 5070 with Opal

Lenght (L) mm		Power W	Lumen lm	Efficiency lm/W
600	MP	13	1235	98
	HP	18	1764	98
1000	MP	21	2058	98
	HP	30	2940	98
1200	MP	25	2470	98
	HP	36	3528	98
1500	MP	32	3087	98
	HP	45	4410	98
2000	MP	42	4116	98
	HP	60	5880	98

Standard Reference Conditions:

Luminous flux values are calculated at 4000K CCT with a system efficacy of 140 lm/W.
 Technical values may change depending on the development of LED and equipment. For detailed and accurate lighting values, please visit our website at www.sonled.com
 Custom length production is available upon request



LNR FLY HR 6617 OL SM
Flying Linear Horizontal Optic Lens
 Surface Mounted



LNR FLY HR 6617 OL SU
Flying Linear Horizontal Optic Lens
 Suspended

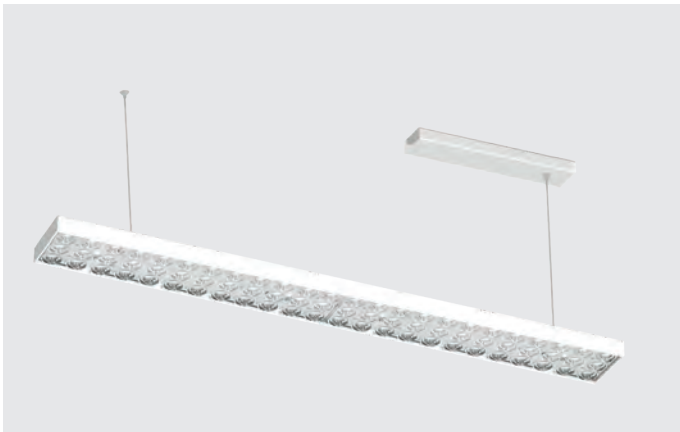

LNR FLY HR 6617 OL RA
Flying Linear Horizontal Optic Lens
 Rail (Track)

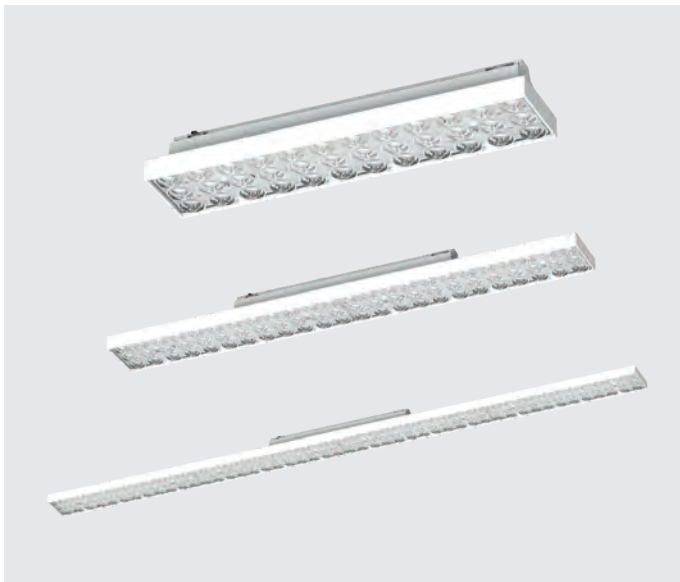

Specifications

Profile Section:	,
Main Body:	Aluminium Profile, static powder painted.
Optic Systems:	Optic Lens (OL)
Lighting Direction:	Direct (D1)
Installation:	Surface Mounted (SM), Suspended (SU), Rail (Track) (SMR)
Beam angle:	120°
Light efficiency:	Avarage 100-160 lm/W
Power:	Medium Power (MP), High Power (HP)
CCT:	2400~6500K , RGB , RGBW
Control & Dimming:	On/Off, Dali, Push, Triac, 1-10V, Remote, Tunable
CRI:	Ra≥80, Ra≥90
Input voltage:	200-240V AC.

Technical Features & Certifications:

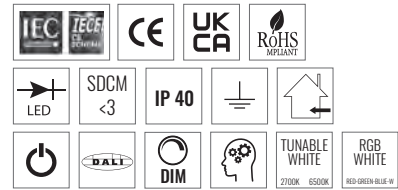

Light Beam

UGR≤19

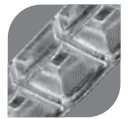
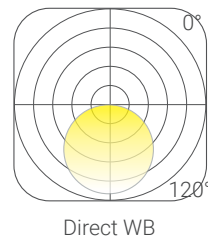

Optic Lens

Main Body Colours:

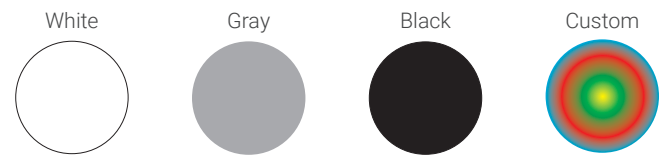

Installation

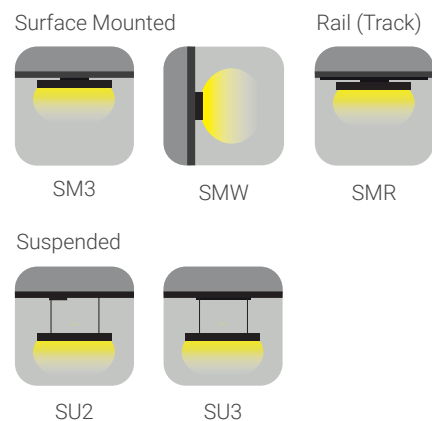

Dimensions

Sections

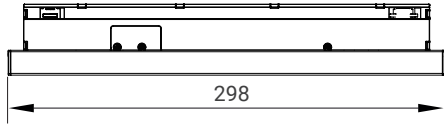
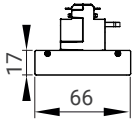

Lenght (L) mm		Power W	Lumen lm	Efficiency lm/W
300	MP	8	1058	126
	HP	11	1436	126
600	MP	17	2117	126
	HP	23	2873	126
1200	MP	34	4234	126
	HP	46	5746	126
1500	MP	42	5292	126
	HP	57	7182	126

Standard Reference Conditions:

Luminous flux values are calculated at 4000K CCT with a system efficacy of 140 lm/W.
 Technical values may change depending on the development of LED and equipment. For detailed and accurate lighting values, please visit our website at www.sonled.com
 Custom length production is available upon request



LNR FLY HR 7030 OD SM
Flying Linear Horizontal Opal Diffuser
 Surface Mounted



LNR FLY HR 7030 OD SU
Flying Linear Horizontal Opal Diffuser
 Suspended

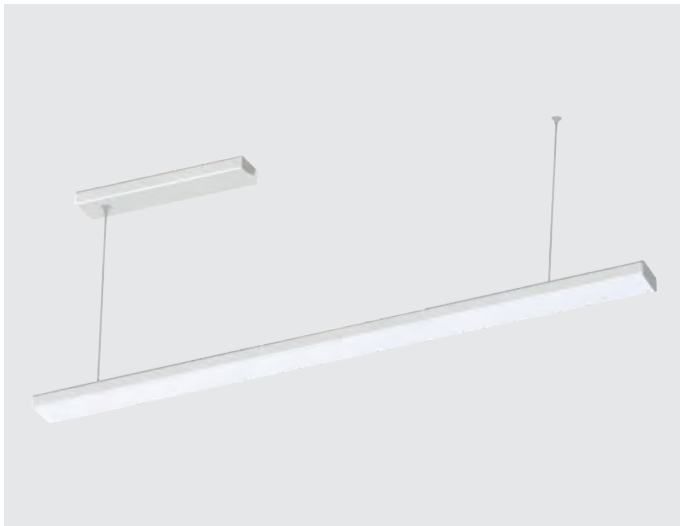

LNR FLY HR 7030 OD RA
Flying Linear Horizontal Opal Diffuser
 Rail (Track)



Specifications

Profile Section: w70*h30 mm,
Main Body: Aluminium Profile, static powder painted.
Optic Systems: Opal Diffuser (OD)
Lighting Direction: Direct (D1)
Installation: Surface Mounted (SM), Suspended (SU), Rail (Track) (SMR)
Beam angle: 140°
Light efficiency: Avarage 100-130 lm/W
Power: Medium Power (MP), High Power (HP)
CCT: 2400~6500K , RGB , RGBW
Control & Dimming: On/Off, Dali, Push, Triac, 1-10V, Remote, Tunable
CRI: Ra≥80, Ra≥90
Input voltage: 200-240V AC.

Technical Features & Certifications:

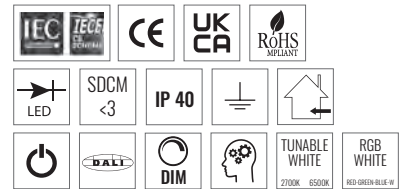

Light Beam

UGR≤20

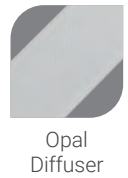
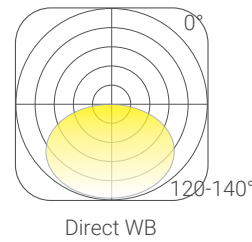

Main Body Colours:

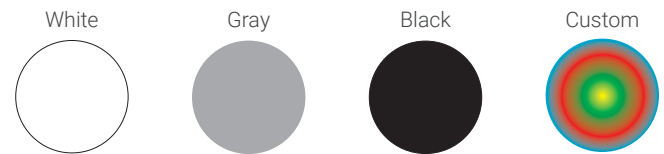

Installation

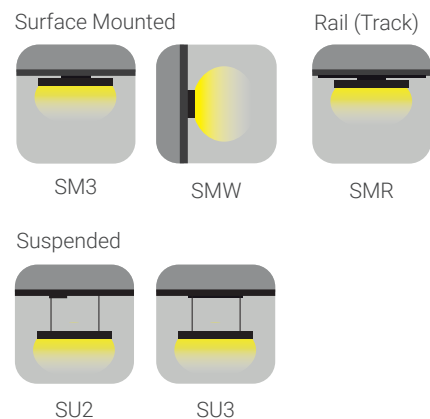

Dimensions

Sections

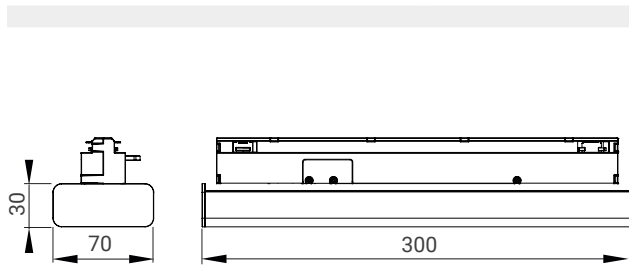

Length (L) mm		Power W	Lumen lm	Efficiency lm/W
300	MP	8	823	98
	HP	11	1117	98
600	MP	17	1646	98
	HP	23	2234	98
1200	MP	34	3293	98
	HP	46	4469	98
1500	MP	42	4116	98
	HP	57	5586	98

Standard Reference Conditions:

Luminous flux values are calculated at 4000K CCT with a system efficacy of 140 lm/W.
 Technical values may change depending on the development of LED and equipment. For detailed and accurate lighting values, please visit our website at www.sonled.com
 Custom length production is available upon request



LNR D60 OD SM
Linear D60 Opal Diffuser
 Surface Mounted

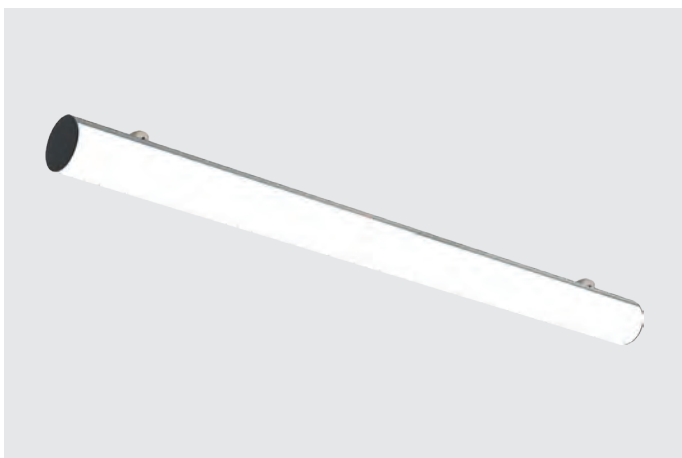

LNR D60 OD SU
Linear D60 Opal Diffuser
 Suspended

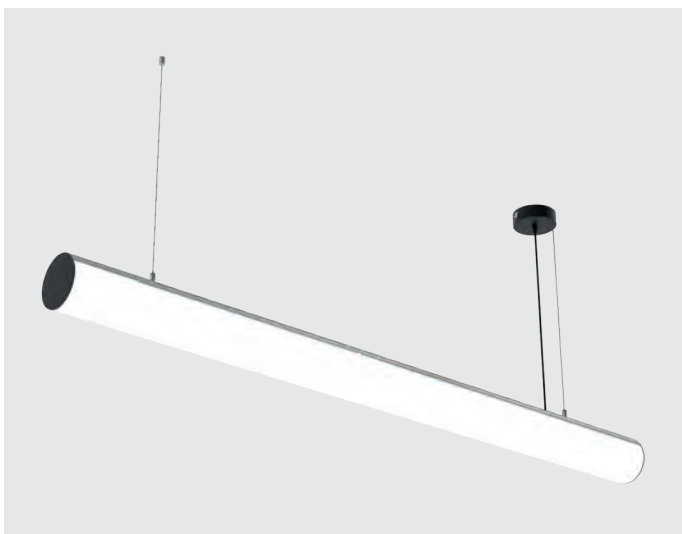

Specifications

- Profile Section:** Ø60 mm,
- Main Body:** Aluminium Profile, static powder painted.
- Optic Systems:** Opal Diffuser (OD)
- Lighting Direction:** Direct (D1)
- Installation:** Surface Mounted (SM), Suspended (SU)
- Beam angle:** 165°
- Light efficiency:** Average 100-130 lm/W
- Power:** Medium Power (MP), High Power (HP)
- CCT:** 2400~6500K , RGB , RGBW
- Control & Dimming:** On/Off, Dali, Push, Triac, 1-10V, Remote, Tunable
- CRI:** Ra≥80, Ra≥90
- Input voltage:** 200-240V AC.

Technical Features & Certifications:

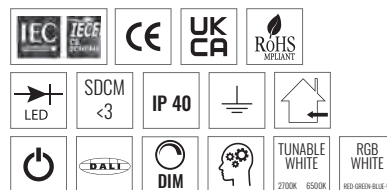

Light Beam

UGR≤20

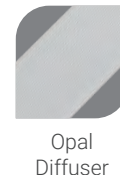
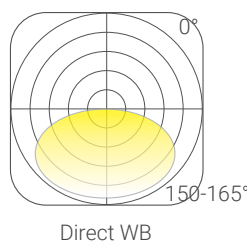

Main Body Colours:

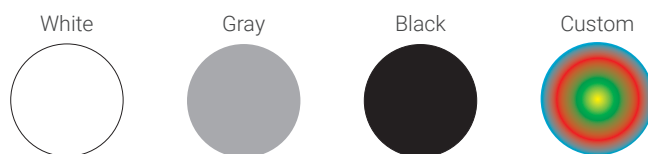

Installation

Surface Mounted



Suspended

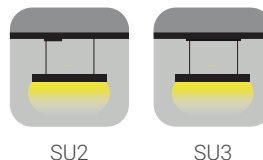

Dimensions

Sections

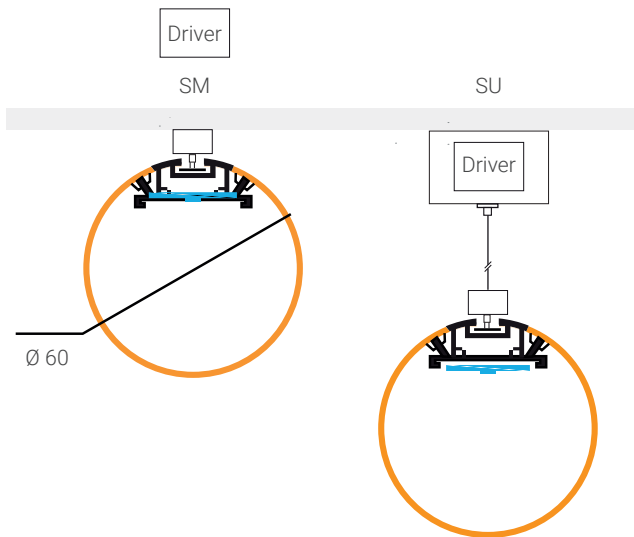

Length (L) mm		Power W	Lumen lm	Efficiency lm/W
600	MP	13	1235	98
	HP	18	1764	98
1000	MP	21	2058	98
	HP	30	2940	98
1200	MP	25	2470	98
	HP	36	3528	98
1500	MP	32	3087	98
	HP	45	4410	98
2000	MP	42	4116	98
	HP	60	5880	98

Standard Reference Conditions:

Luminous flux values are calculated at 4000K CCT with a system efficacy of 140 lm/W. Technical values may change depending on the development of LED and equipment. For detailed and accurate lighting values, please visit our website at www.sonled.com. Custom length production is available upon request.



LNR D85 OD SM
Linear D85 Opal Diffuser
 Surface Mounted

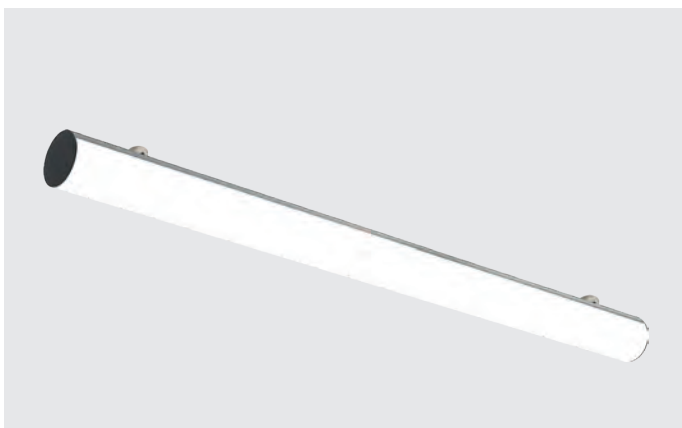

LNR D85 OD SU
Linear D85 Opal Diffuser
 Suspended

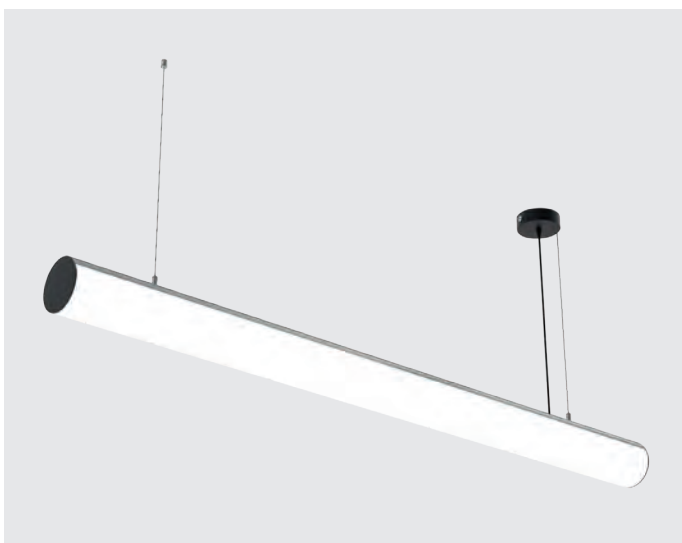

Specifications

- Profile Section:** Ø85 mm
- Main Body:** Aluminium Profile, static powder painted.
- Optic Systems:** Opal Diffuser (OD)
- Lighting Direction:** Direct (D1)
- Installation:** Surface Mounted (SM), Suspended (SU)
- Beam angle:** 150°
- Light efficiency:** Average 100-130 lm/W
- Power:** Medium Power (MP), High Power (HP)
- CCT:** 2400~6500K, RGB, RGBW
- Control & Dimming:** On/Off, Dali, Push, Triac, 1-10V, Remote, Tunable
- CRI:** Ra≥80, Ra≥90
- Input voltage:** 200-240V AC.

Technical Features & Certifications:

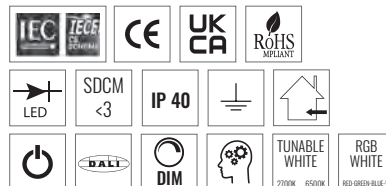

Light Beam

UGR≤20

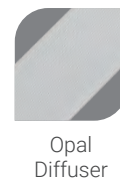
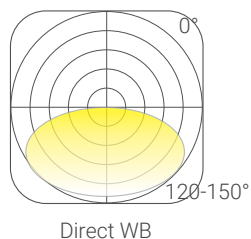

Main Body Colours:

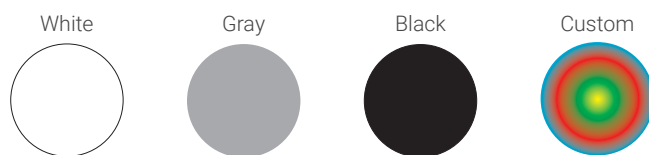

Installation

Surface Mounted

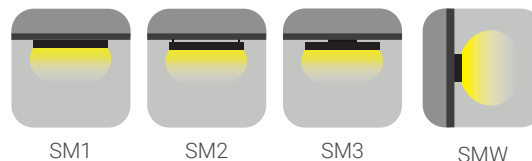

Suspended

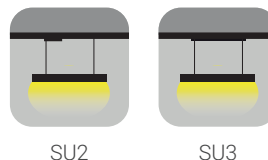

Dimensions

Sections

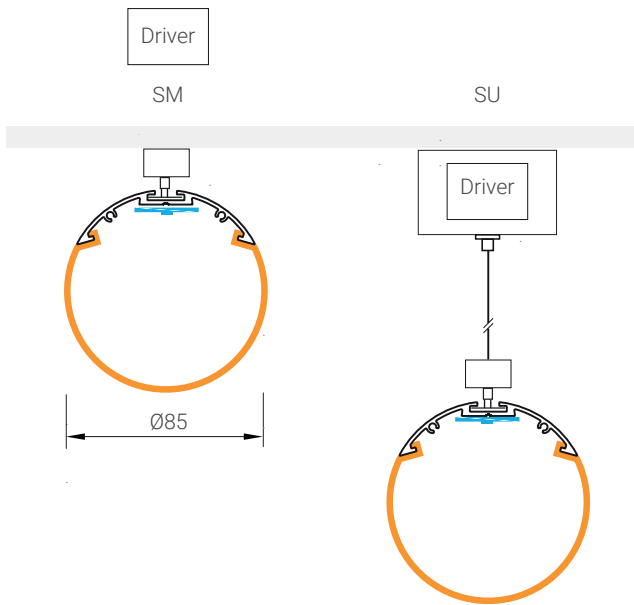

Length (L) mm		Power W	Lumen lm	Efficiency lm/W
600	MP	13	1235	98
	HP	18	1764	98
1000	MP	21	2058	98
	HP	30	2940	98
1200	MP	25	2470	98
	HP	36	3528	98
1500	MP	32	3087	98
	HP	45	4410	98
2000	MP	42	4116	98
	HP	60	5880	98

Standard Reference Conditions:

Luminous flux values are calculated at 4000K CCT with a system efficacy of 140 lm/W. Technical values may change depending on the development of LED and equipment. For detailed and accurate lighting values, please visit our website at www.sonled.com. Custom length production is available upon request.



LNR FLY VR SM Flying Linear Vertical Surface mounted

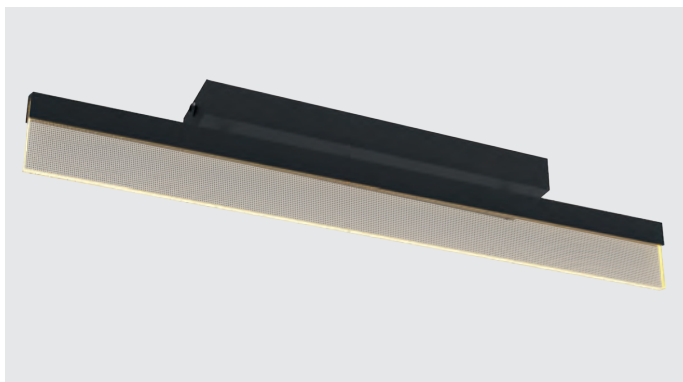

LNR FLY VR SU Flying Linear Vertical Suspended



Specifications

Profile Section:	w13*h20 + 8*30-50-100 or custom wave
Main Body:	Aluminium Profile, static powder painted.
Optic Systems:	Engraved by galvo-laser acrylic (PMMA)
Lighting Direction:	Direct (D1)
Installation:	Surface Mounted (SM), Suspended (SU)
Beam angle:	150°-165°
Light efficiency:	Avarage 100-160 lm/W
Power:	Low Power (LP), Medium Power (MP)
CCT:	2400~6500K , RGB , RGBW
Control & Dimming:	On/Off, Dali, Push, Triac, 1-10V, Remote, Tunable
CRI:	Ra≥80, Ra≥90
Input voltage:	200-240V AC.

Technical Features & Certifications:

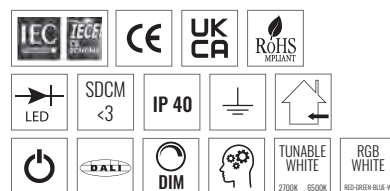

Light Beam

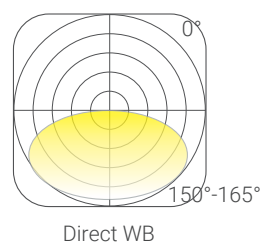

Diffusers

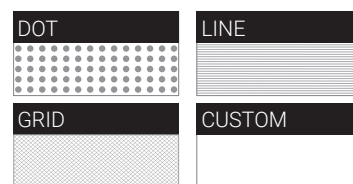

Main Body Colours:

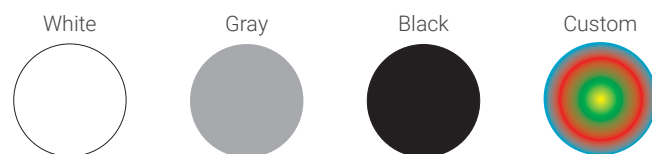

Installation

Surface Mounted

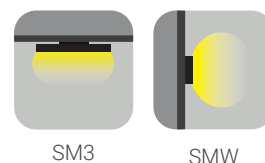

Suspended

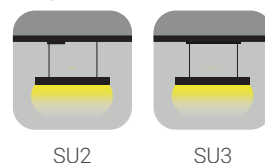

Dimensions

Sections

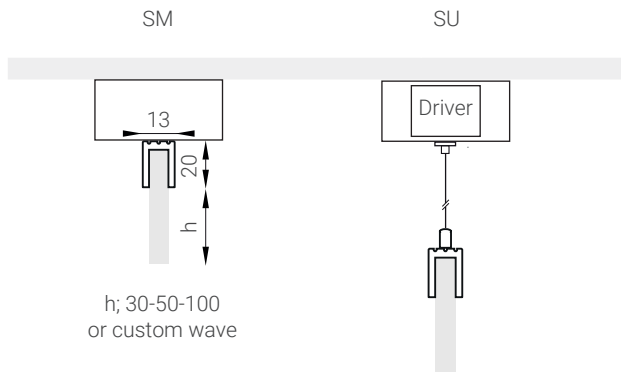

Lenght (L) mm		Power W	Lumen lm	Efficiency lm/W
610	LP	9	1114	126
	MP	13	1614	126
1010	LP	15	1845	126
	MP	21	2672	126
1210	LP	18	2211	126
	MP	25	3202	126
1510	LP	22	2759	126
	MP	32	3995	126
2010	LP	29	3672	126
	MP	42	5318	126

Standard Reference Conditions:

Luminous flux values are calculated at 4000K CCT with a system efficacy of 140 lm/W.

Technical values may change depending on the development of LED and equipment. For detailed and accurate lighting values, please visit our website at www.sonled.com

Custom length production is available upon request



LNR FLY WN SM
Flying Linear Wings
 Surface Mounted

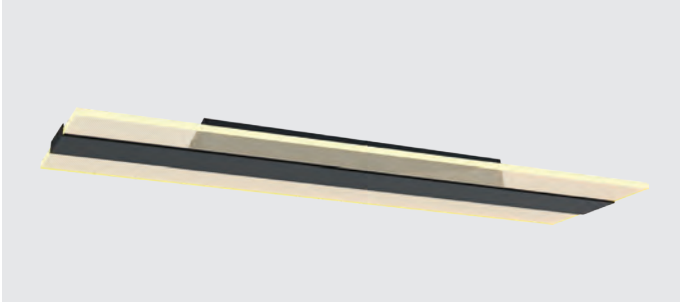

LNR FLY WN SU
Flying Linear Wings
 Suspended



Specifications

- Profile Section:** w150*h10 mm
- Main Body:** Steel+Aluminium Profile, static powder painted.
- Optic Systems:** Engraved by galvo-laser acrylic (PMMA)
- Lighting Direction:** Direct (D1)
- Installation:** Surface Mounted (SM), Suspended (SU)
- Beam angle:** 150°
- Light efficiency:** Avarage 100-160 lm/W
- Power:** Low Power (LP), Medium Power (MP)
- CCT:** 2400~6500K , RGB , RGBW
- Control & Dimming:** On/Off, Dali, Push, Triac, 1-10V, Remote, Tunable
- CRI:** Ra≥80, Ra≥90
- Input voltage:** 200-240V AC.

Technical Features & Certifications:

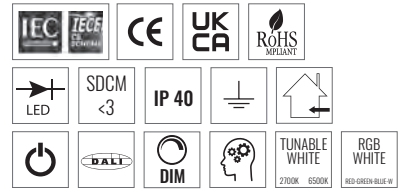

Light Beam

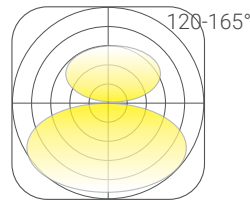

Direct WB/ 120-165°
 Indirect

Diffusers

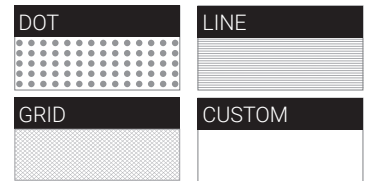

Main Body Colours:

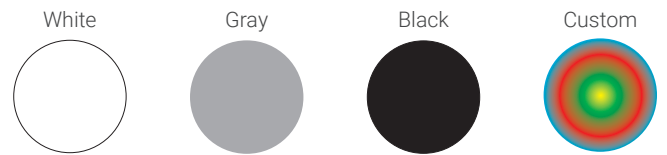

Installation

Surface Mounted

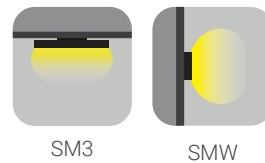

Suspended

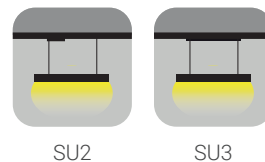

Dimensions

Sections

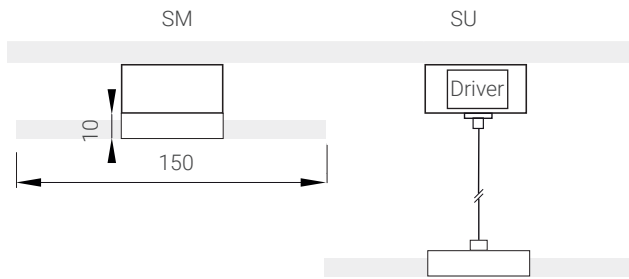

Lenght (L) mm		Power W	Lumen lm	Efficiency lm/W
610	LP	18	2229	126
	MP	26	3228	126
1010	LP	29	3691	126
	MP	42	5345	126
1210	LP	35	4421	126
	MP	51	6403	126
1510	LP	44	5518	126
	MP	63	7991	126
2010	LP	58	7345	126
	MP	84	10637	126

Standard Reference Conditions:

Luminous flux values are calculated at 4000K CCT with a system efficacy of 140 lm/W.
 Technical values may change depending on the development of LED and equipment. For detailed and accurate lighting values, please visit our website at www.sonled.com
 Custom length production is available upon request

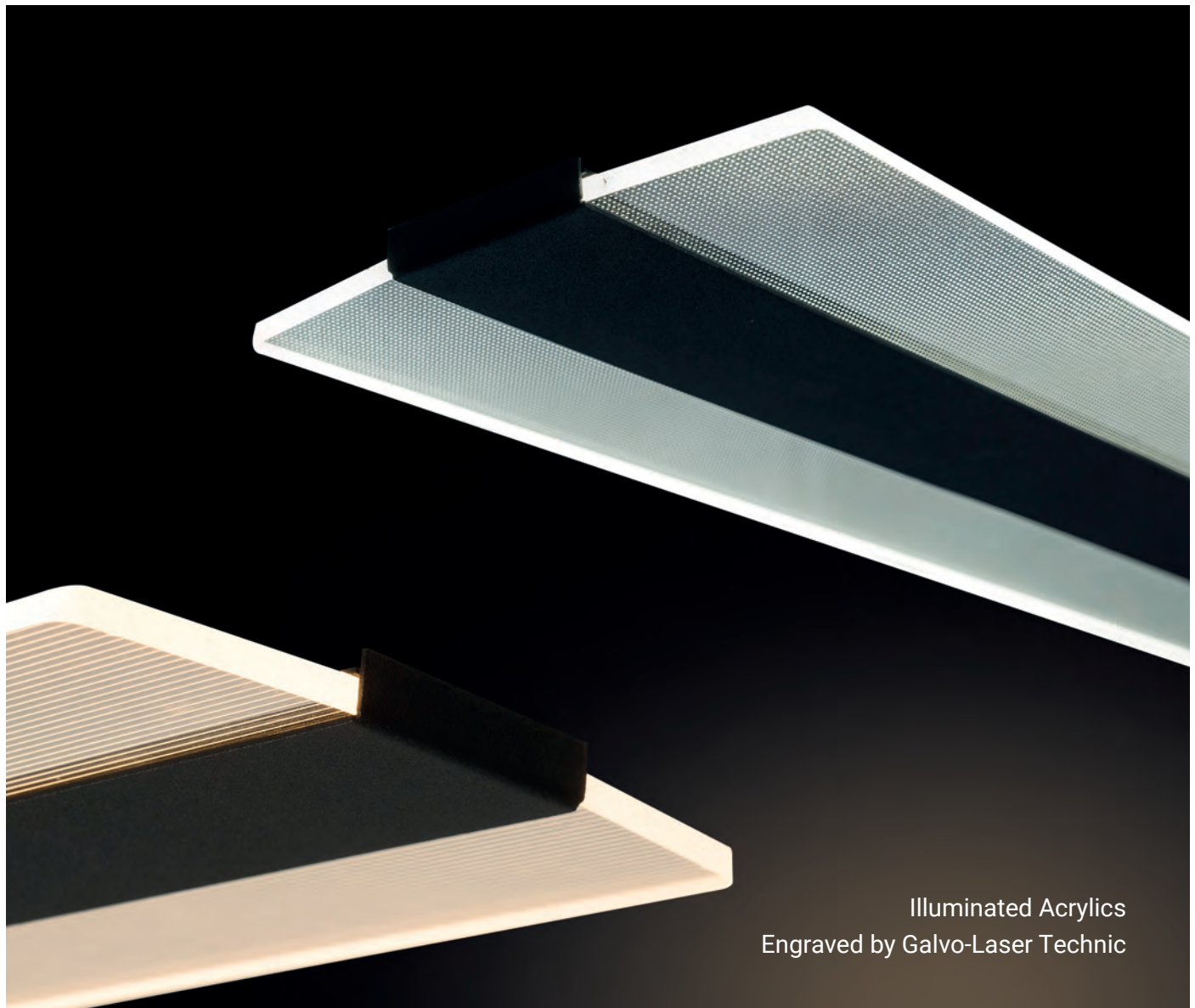

Illuminated Acrylics
 Engraved by Galvo-Laser Technic

ROUNDS

ROUNDS

Circular Light. Architectural Balance.

Round LED lighting brings softness and structure into contemporary spaces. Unlike linear forms, circular luminaires create a natural focal point – balanced, calm, and complete.

The SONLED Rounds collection includes both suspended ring LED systems and compact circular ceiling luminaires, designed for modern architectural lighting projects. From large statement ring lights for lobbies and atriums to minimal surface-mounted circle fixtures for offices and residential interiors, each model integrates seamlessly into the space.

Our circular lighting systems combine uniform light distribution, visual comfort, and precise optical control. With multiple sizes, mounting options, and customizable finishes, they adapt easily to commercial, hospitality, and residential environments.

Timeless geometry.
Controlled illumination.
Architectural presence.



RRS 5050 RC / RRS 8080 RC / RRS 9999 RC Round Ring Standard Recessed

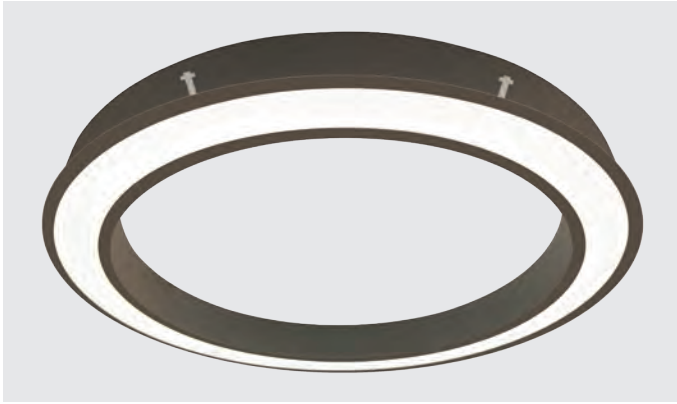

For recessed models, the ceiling cutting dimension should be 25 mm less than the product diameter.

RRS 5050 SM / RRS 8080 SM / RRS 9999 SM Round Ring Standard Surface Mounted



RRS 5050 SU / RRS 8080 SU / RRS 9999 SU Round Ring Standard Suspended



Specifications

- Profile Section:** w50*h50 mm, w80*h80 mm, w100*h100 mm, or custom width
- Main Body:** Aluminium Profile, Special form cutting steel and aluminium sheet static powder painted.
- Optic Systems:** Opal Diffuser (OD), Opal Prismatic Diffuser (OP), Clear Prismatic Diffuser (CP), Micro Prismatic Diffuser (MP), Clear Prismatic (CP) + Opal Diffuser (OD)
- Lighting Direction:** Direct (D1)
- Installation:** Recessed (RC), Surface Mounted (SM) Suspended (SU)
- Beam angle:** 120°
- Light efficiency:** Average 100-130 lm/W
- Power:** Low Power (LP), Medium Power (MP), High Power (LP)
- CCT:** 2400~6500K, RGB, RGBW
- Control & Dimming:** On/Off, Dali, Push, Triac, 1-10V, Remote, Tunable
- CRI:** Ra≥80, Ra≥90
- Input voltage:** 200-240V AC.

Technical Features & Certifications:

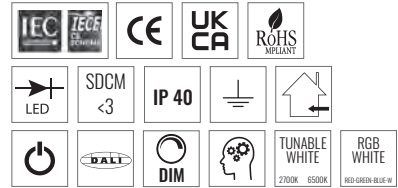

Light Beam

UGR≤19 & UGR≤20

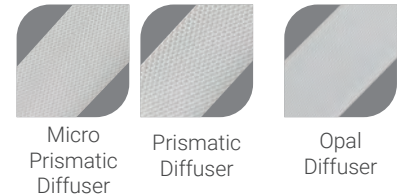
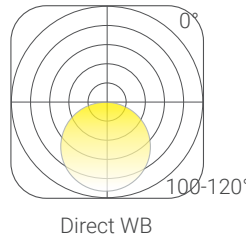

Main Body Colours:

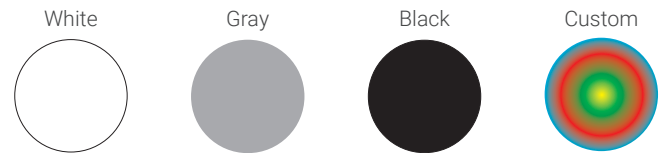

Installation

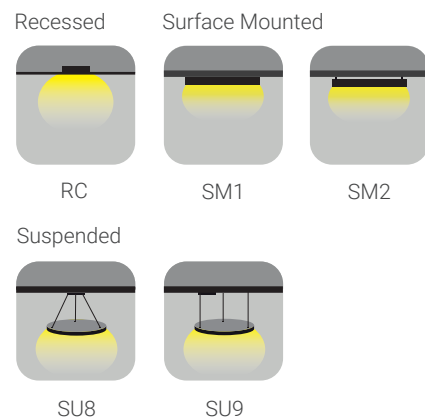

Dimensions

Sections

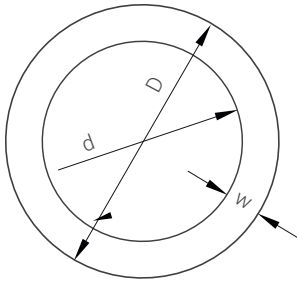

w 50 h 50 (5050)
w 80 h 80 (8080)
w 100 h 100 (9999)
or
custom width

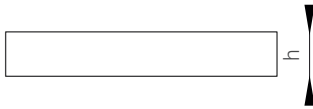

Recessed Profile Sections

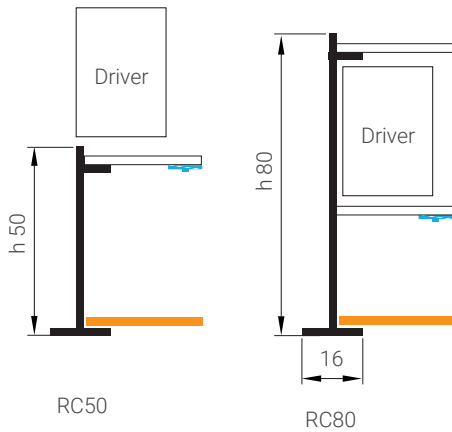

Surface Mounted and Suspended Profile Sections

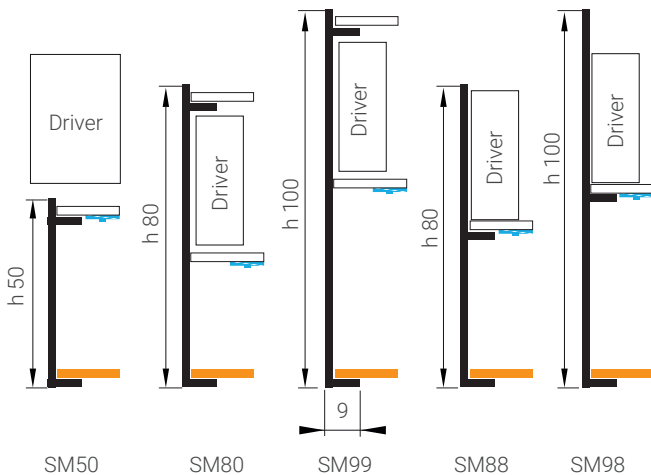

Standard Reference Conditions:

Luminous flux values are calculated at 4000K CCT with a system efficacy of 140 lm/W.

Technical values may change depending on the development of LED and equipment. For detailed and accurate lighting values, please visit our website at www.sonled.com

Custom length production is available upon request

Diameter (Ø) D-d mm		w mm	Power W	Lumen lm	Efficiency lm/W
Ø400-Ø300	LP	50	16	1562	98
	MP	50	23	2262	98
Ø600-Ø500	LP	50	25	2454	98
	MP	50	36	3554	98
Ø900-Ø800	LP	50	39	3793	98
	MP	50	56	5493	98
Ø1200-Ø1100	LP	50	52	5131	98
	MP	50	76	7431	98
Ø1500-Ø1400	LP	50	66	6470	98
	MP	50	96	9370	98
Ø2000-Ø1900	LP	50	89	8701	98
	MP	50	129	12601	98

Diameter (Ø) mm		w mm	Power W	Lumen lm	Efficiency lm/W
Ø600-Ø440	LP	80	24	2320	98
	MP	80	34	3360	98
	HP	80	49	4800	98
Ø900-Ø740	LP	80	37	3659	98
	MP	80	54	5299	98
	HP	80	77	7570	98
Ø1200-Ø1040	LP	80	51	4997	98
	MP	80	74	7238	98
	HP	80	106	10339	98
Ø1500-Ø1340	LP	80	65	6336	98
	MP	80	94	9176	98
	HP	80	134	13109	98
Ø2000-Ø1840	LP	80	87	8567	98
	MP	80	127	12407	98
	HP	80	181	17725	98

Diameter (Ø) mm		w mm	Power W	Lumen lm	Efficiency lm/W
Ø600-Ø400	MP	100	33	3231	98
	HP	100	47	4616	98
Ø900-Ø700	MP	100	53	5170	98
	HP	100	75	7385	98
Ø1200-Ø1000	MP	100	73	7108	98
	HP	100	104	10155	98
Ø1500-Ø1300	MP	100	92	9047	98
	HP	100	132	12924	98
Ø2000-Ø1800	MP	100	125	12278	98
	HP	100	179	17540	98

RRS 8080 D2 SM / RRS 9999 D2 SM
Round Ring Standard Direct/Indirect
 Surface Mounted

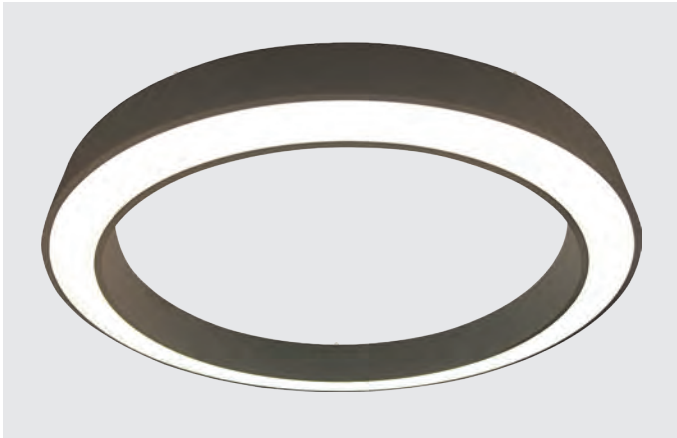

RRS 8080 D2 SU / RRS 9999 D2 SU
Round Ring Standard Direct/Indirect
 Suspended

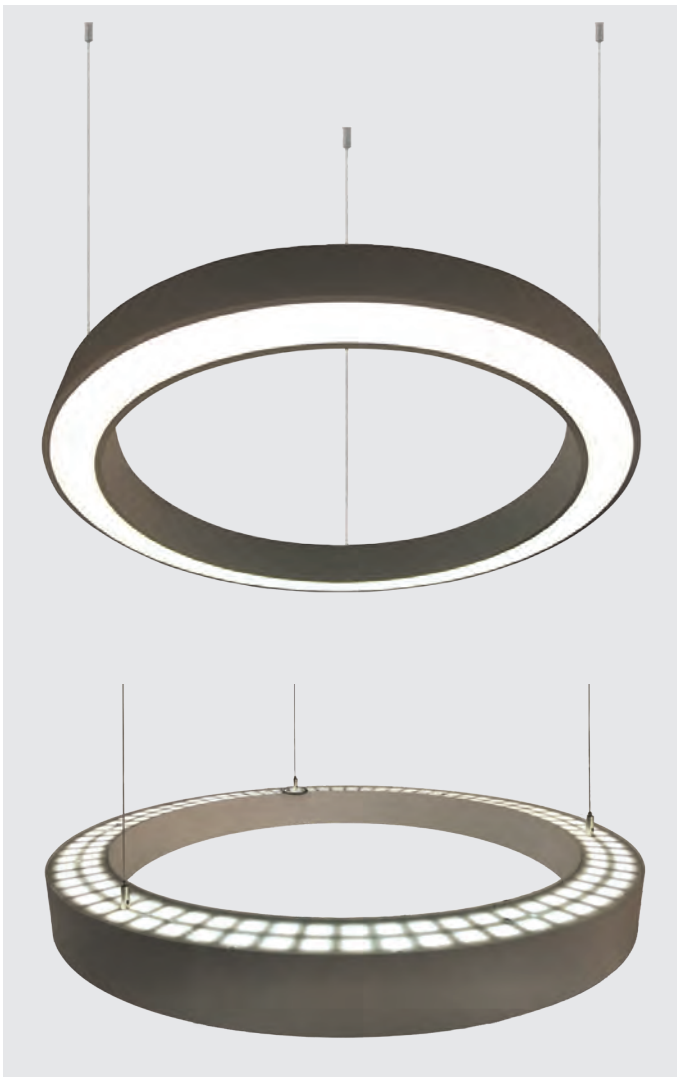

Specifications

- Profile Section:** w80*h80 mm, w100*h100 mm, or custom width
- Main Body:** Aluminium Profile, Special form cutting steel and aluminium sheet static powder painted.
- Optic Systems:** Opal Diffuser (OD), Opal Prismatic Diffuser (OP), Clear Prismatic Diffuser (CP), Micro Prismatic Diffuser (MP), Clear Prismatic (CP) + Opal Diffuser (OD)
- Lighting Direction:** Direct/Indirect (D2)
- Installation:** Surface Mounted (SM), Suspended (SU)
- Beam angle:** 120°
- Light efficiency:** Average 100-130 lm/W
- Power:** Low Power (LP), Medium Power (MP), High Power (LP)
- CCT:** 2400~6500K, RGB, RGBW
- Control & Dimming:** On/Off, Dali, Push, Triac, 1-10V, Remote, Tunable
- CRI:** Ra≥80, Ra≥90
- Input voltage:** 200-240V AC.

Technical Features & Certifications:

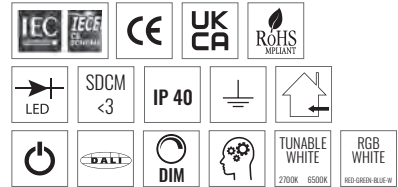

Light Beam

UGR≤19 & UGR≤20

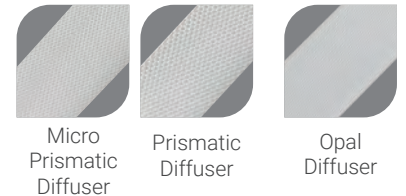
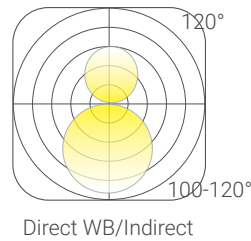

Main Body Colours:

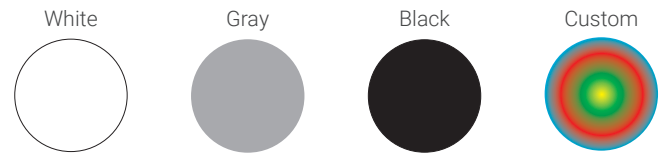

Installation

Surface Mounted



Suspended

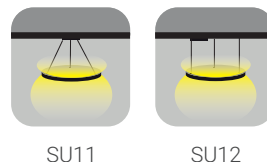

Dimensions

Sections

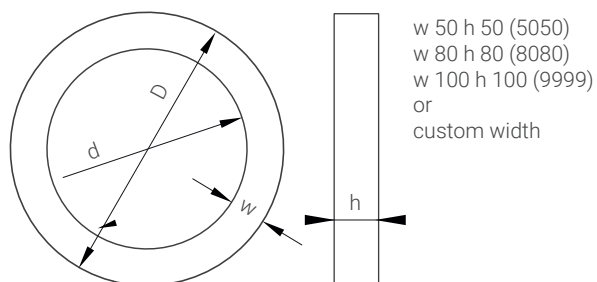

Surface Mounted and Suspended Profile Sections

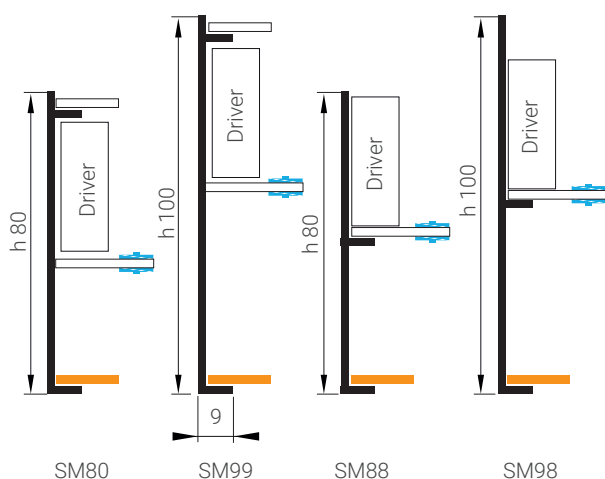

Standard Reference Conditions:

Luminous flux values are calculated at 4000K CCT with a system efficacy of 140 lm/W.

Technical values may change depending on the development of LED and equipment. For detailed and accurate lighting values, please visit our website at www.sonled.com

Custom length production is available upon request

Diameter (Ø) mm		w mm	Power (D/I=T) W	Lumen lm	Efficiency lm/W
Ø600-Ø440	LP	80	24/24=47	4640	98
	MP	80	34/24=58	5681	98
	HP	80	49/24=73	7121	98
Ø900-Ø740	LP	80	37/37=75	7318	98
	MP	80	54/37=91	8958	98
	HP	80	77/37=115	11229	98
Ø1200-Ø1040	LP	80	51/51=102	9995	98
	MP	80	74/51=125	12235	98
	HP	80	106/51=156	15337	98
Ø1500-Ø1340	LP	80	65/65=129	12672	98
	MP	80	94/65=158	15512	98
	HP	80	134/65=198	19445	98
Ø2000-Ø1840	LP	80	87/87=175	17134	98
	MP	80	127/87=214	20974	98
	HP	80	181/87=268	26292	98

Diameter (Ø) mm		w mm	Power (D/I=T) W	Lumen lm	Efficiency lm/W
Ø600-Ø400	MP	100	33/23=56	5462	98
	HP	100	47/23=70	6847	98
Ø900-Ø700	MP	100	53/36=89	8739	98
	HP	100	75/36=112	10955	98
Ø1200-Ø1000	MP	100	73/50=123	12016	98
	HP	100	104/50=154	15063	98
Ø1500-Ø1300	MP	100	92/64=156	15294	98
	HP	100	132/64=196	19171	98
Ø2000-Ø1800	MP	100	125/87=212	20756	98
	HP	100	179/87=265	26018	98



RRT 4040 RC
Round Ring Trimless
 Recessed

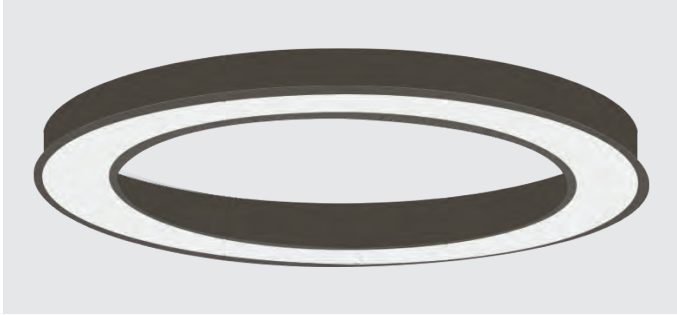

For recessed models, the ceiling cutting dimension should be 25 mm less than the product diameter.

RRT 4040 SM / RRT 7575 SM
Round Ring Trimless
 Surface Mounted

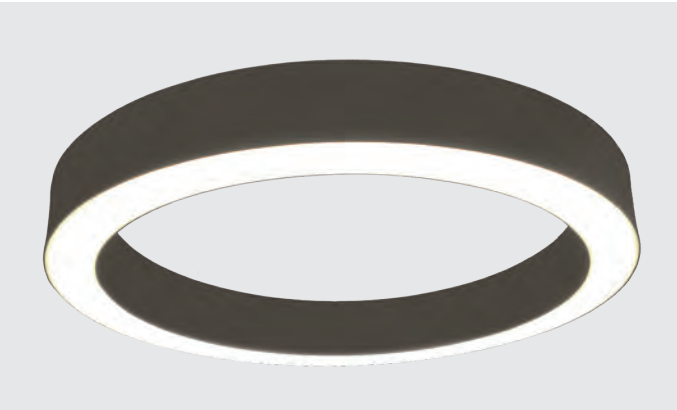

RRT 4040 SU / RRT 7575 SU
Round Ring Trimless
 Suspended



Specifications

- Profile Section:** w40*h40 mm, w75*h75 mm,
- Main Body:** Aluminium Profile, Special form cutting steel and aluminium sheet static powder painted.
- Optic Systems:** Opal Diffuser (OD), Opal Prismatic Diffuser (OP), Clear Prismatic Diffuser (CP), Micro Prismatic Diffuser (MP), Clear Prismatic (CP) + Opal Diffuser (OD)
- Lighting Direction:** Direct (D1)
- Installation:** Recessed (RC), Surface Mounted (SM) Suspended (SU)
- Beam angle:** 120°
- Light efficiency:** Average 100-130lm/W
- Power:** Low Power (LP), Medium Power (MP), High Power (LP)
- CCT:** 2400~6500K , RGB , RGBW
- Control & Dimming:** On/Off, Dali, Push, Triac, 1-10V, Remote, Tunable
- CRI:** Ra≥80, Ra≥90
- Input voltage:** 200-240V AC.

Technical Features & Certifications:

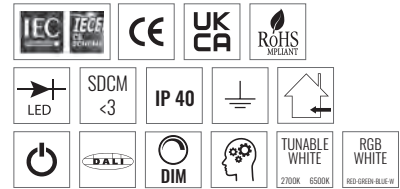

Light Beam

UGR≤19 & UGR≤20

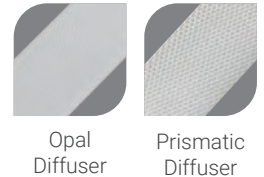
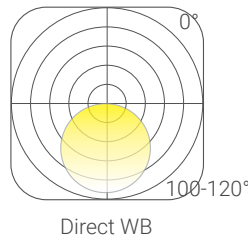

Main Body Colours:

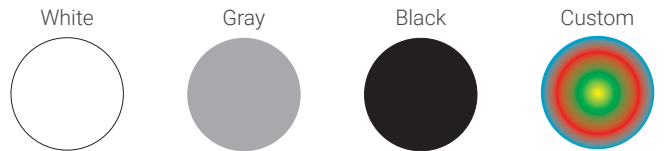

Installation

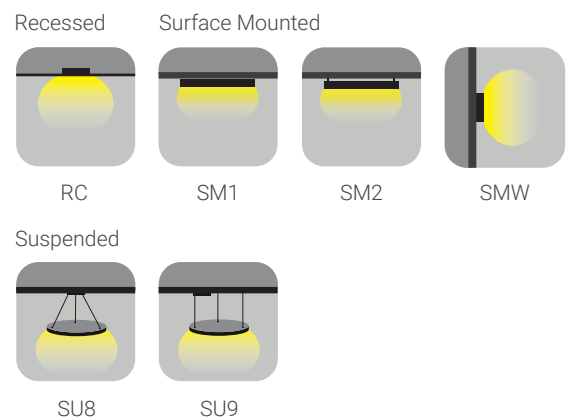

Dimensions

Sections

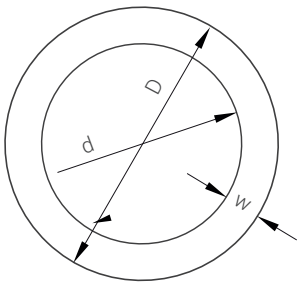

w 40 h 40 (4040)
w 75 h 75 (7575)
or
custom width

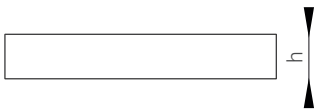

Diameter (Ø) mm		w mm	Power W	Lumen lm	Efficiency lm/W
Ø400-Ø320	LP	40	16	1606	98
	MP	40	24	2326	98
Ø600-Ø520	LP	40	25	2499	98
	MP	40	37	3619	98
Ø900-Ø820	LP	40	39	3837	98
	MP	40	57	5557	98
Ø1200-Ø1120	LP	40	53	5176	98
	MP	40	76	7496	98
Ø1500-Ø1420	LP	40	66	6514	98
	MP	40	96	9435	98
Ø2000-Ø1920	LP	40	86	8444	98
	MP	40	129	12666	98

Recessed, Surface Mounted and Suspended Profile Sections

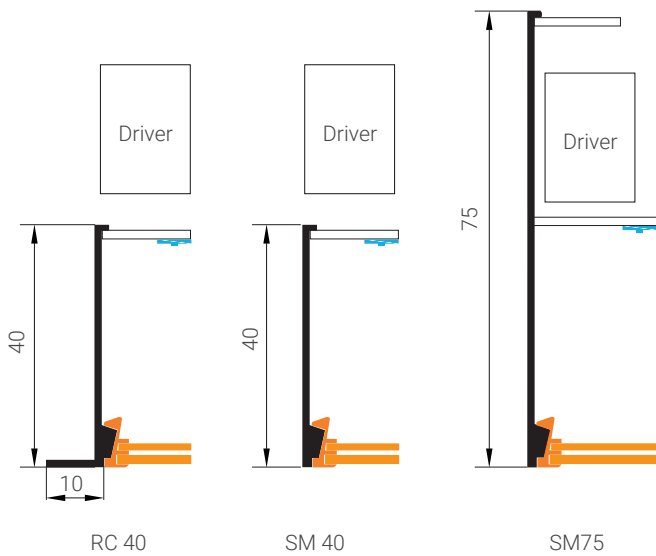

Diameter (Ø) mm		w mm	Power W	Lumen lm	Efficiency lm/W
Ø400-Ø250	LP	75	15	1450	98
	MP	75	21	2100	98
	HP	75	31	3000	98
Ø600-Ø450	LP	75	24	2343	98
	MP	75	35	3393	98
	HP	75	49	4847	98
Ø900-Ø750	LP	75	38	3681	98
	MP	75	54	5331	98
	HP	75	78	7616	98
Ø1200-Ø1050	LP	75	51	5020	98
	MP	75	74	7270	98
	HP	75	106	10386	98
Ø1500-Ø1350	LP	75	65	6358	98
	MP	75	94	9209	98
	HP	75	134	13155	98
Ø2000-Ø1850	LP	75	89	8708	98
	MP	75	127	12440	98
	HP	75	181	17771	98



Standard Reference Conditions:

Luminous flux values are calculated at 4000K CCT with a system efficacy of 140 lm/W.
Technical values may change depending on the development of LED and equipment. For detailed and accurate lighting values, please visit our website at www.sonled.com
Custom length production is available upon request

RRT 7575 D2 SM
Round Ring Trimless Direct/Indirect
 Surface Mounted



RRT 7575 D2 SU
Round Ring Trimless Direct/Indirect
 Suspended



Specifications

- Profile Section:** w75*h75 mm
- Main Body:** Aluminium Profile, Special form cutting steel and aluminium sheet static powder painted.
- Optic Systems:** Opal Diffuser (OD), Opal Prismatic Diffuser (OP), Clear Prismatic Diffuser (CP), Micro Prismatic Diffuser (MP), Clear Prismatic (CP) + Opal Diffuser (OD)
- Lighting Direction:** Direct/Indirect (D2)
- Installation:** Surface Mounted (SM), Suspended (SU)
- Beam angle:** 120°
- Light efficiency:** Average 100-130 lm/W
- Power:** Low Power (LP), Medium Power (MP), High Power (LP)
- CCT:** 2400~6500K , RGB , RGBW
- Control & Dimming:** On/Off, Dali, Push, Triac, 1-10V, Remote, Tunable
- CRI:** Ra≥80, Ra≥90
- Input voltage:** 200-240V AC.

Technical Features & Certifications:

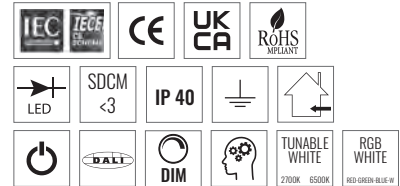

Light Beam

UGR≤19 & UGR≤20

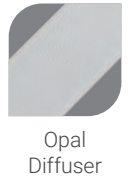
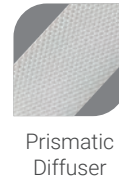
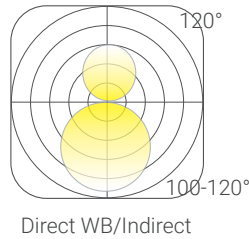

Main Body Colours:

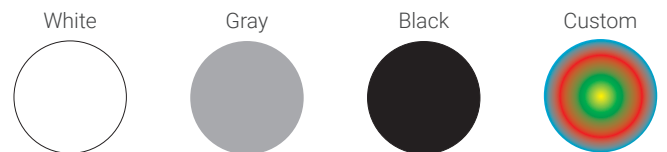

Installation

Surface Mounted



Suspended

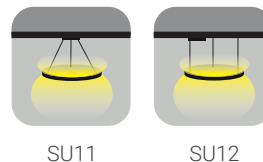

Dimensions

Sections

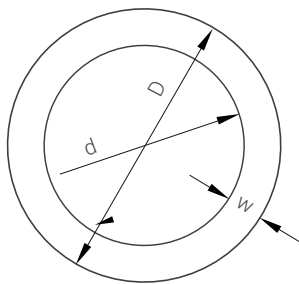

w 75 h 75 (7575)
or
custom width



Surface Mounted and Suspended Profile Sections

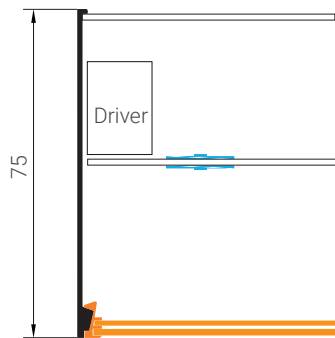

SM75 - SU75

Diameter (Ø) mm		w mm	Power (D/I=T) W	Lumen lm	Efficiency lm/W
Ø400-Ø250	LP	75	15/15=30	2900	98
	MP	75	21/15=36	3550	98
	HP	75	31/15=45	4450	98
Ø600-Ø450	LP	75	24/24=48	4685	98
	MP	75	35/24=59	5735	98
	HP	75	49/24=73	7189	98
Ø900-Ø750	LP	75	38/38=75	7362	98
	MP	75	54/38=92	9012	98
	HP	75	78/38=115	11297	98
Ø1200-Ø1050	LP	75	51/51=102	10039	98
	MP	75	74/51=125	12290	98
	HP	75	106/51=157	15405	98
Ø1500-Ø1350	LP	75	65/65=130	12717	98
	MP	75	94/65=159	15567	98
	HP	75	134/65=199	19513	98
Ø2000-Ø1850	LP	75	88/88=175	17178	98
	MP	75	127/88=215	21029	98
	HP	75	181/88=269	26360	98

Standard Reference Conditions:

Luminous flux values are calculated at 4000K CCT with a system efficacy of 140 lm/W.

Technical values may change depending on the development of LED and equipment. For detailed and accurate lighting values, please visit our website at www.sonled.com

Custom length production is available upon request



RRA 5060 SM
Round Ring Acrylic
 Surface Mounted

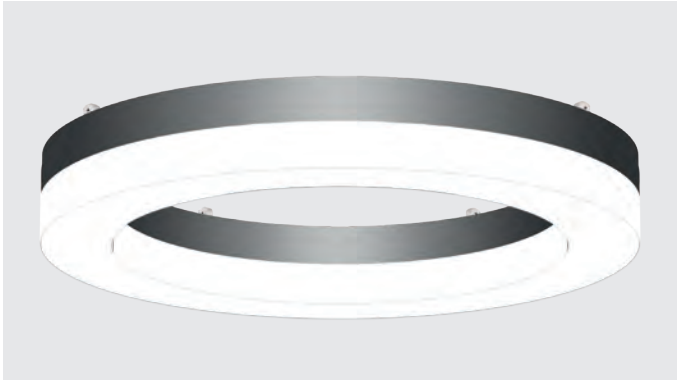

RRA 5060 SU
Round Ring Acrylic
 Suspended



Specifications

- Profile Section:** w50*h60 mm
- Main Body:** Special form steel and static powder painted.
- Optic Systems:** PMMA Acrylic diffuser (opal 70% - 50%)
- Lighting Direction:** Direct (D1)
- Installation:** Surface Mounted (SM), Suspended (SU)
- Beam angle:** 120°
- Light efficiency:** Avarage 100-120lm/W
- Power:** Medium Power (MP), High Power (LP)
- CCT:** 2400~6500K , RGB , RGBW
- Control & Dimming:** On/Off, Dali, Push, Triac, 1-10V, Remote, Tunable
- CRI:** Ra≥80, Ra≥90
- Input voltage:** 200-240V AC.

Technical Features & Certifications:

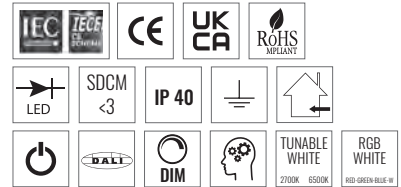

Light Beam

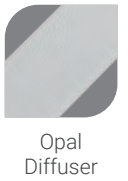
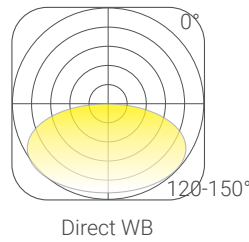

Main Body Colours:

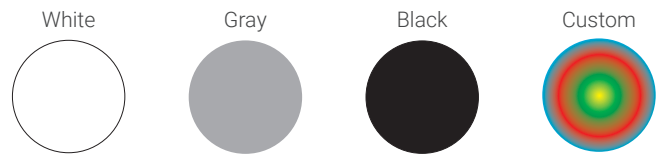

Installation

Surface Mounted

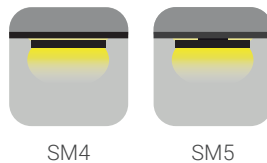

Suspended

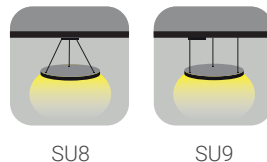

Dimensions

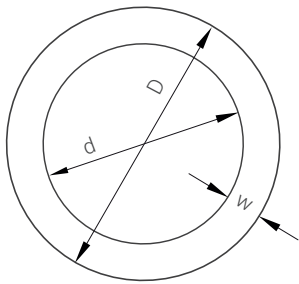

Sections

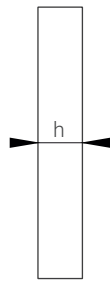

Surface Mounted and Suspended Sections

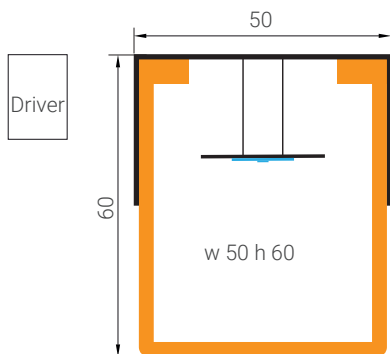

Diameter (Ø) mm		w mm	Power W	Lumen lm	Efficiency lm/W
Ø600-Ø500	MP	50	36	3046	84
	HP	50	52	4352	84
Ø900-Ø800	MP	50	56	4708	84
	HP	50	80	6726	84
Ø1200-Ø1100	MP	50	76	6370	84
	HP	50	108	9100	84
Ø1500-Ø1400	MP	50	96	8031	84
	HP	50	137	11474	84

Standard Reference Conditions:

Luminous flux values are calculated at 4000K CCT with a system efficacy of 140 lm/W.
 Technical values may change depending on the development of LED and equipment. For
 detailed and accurate lighting values, please visit our website at www.sonled.com
 Custom length production is available upon request



RRR 2640 SM
Round Ring Reflect Lens
 Surface Mounted



RRR 2640 SU
Round Ring Reflect Lens
 Suspended



Specifications

- Profile Section:** w26*h40 mm
- Main Body:** Aluminium Profile, static powder painted.
- Optic Systems:** Reflect Lens (RL)
- Lighting Direction:** Direct (D1)
- Installation:** Surface Mounted (SM), Suspended (SU)
- Beam angle:** 24° - 36° - 48°
- Light efficiency:** Average 100-160 lm/W
- Power:** Low Power (LP), Medium Power (MP),
- CCT:** 2400~6500K , RGB , RGBW
- Control & Dimming:** On/Off, Dali, Push, Triac, 1-10V, Remote, Tunable
- CRI:** Ra≥80, Ra≥90
- Input voltage:** 200-240V AC.

Technical Features & Certifications:

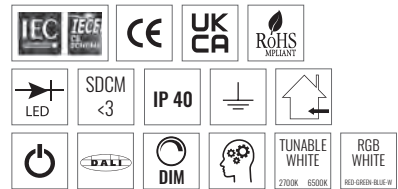

Light Beam

UGR≤15

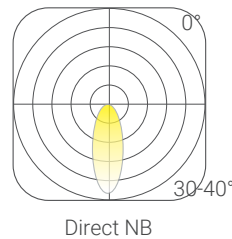

Reflect Lens

Main Body Colours:

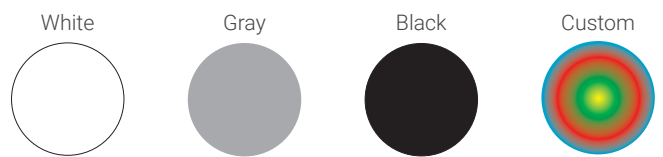

Installation

Surface Mounted



SM2

Suspended



SU8

SU9

Dimensions

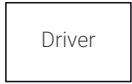
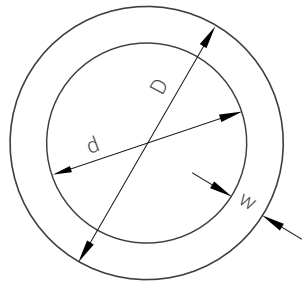

Sections

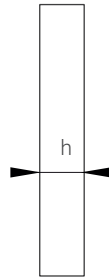

w 26 h 40

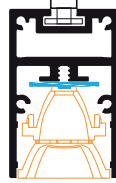
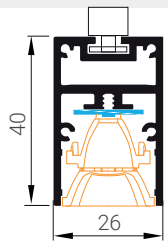
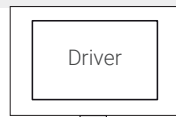

Diameter (Ø) mm		Power W	Lumen lm	Efficiency lm/W
Ø400	LP	18	2339	133
	MP	35	4677	133
Ø600	LP	26	3508	133
	MP	53	7016	133
Ø800	LP	35	4677	133
	MP	70	9355	133
Ø1200	LP	53	7016	133
	MP	106	14032	133
Ø1500	LP	66	8770	133
	MP	132	17540	133
Ø1800	LP	79	10524	133
	MP	158	21048	133

Standard Reference Conditions:

Luminous flux values are calculated at 4000K CCT with a system efficacy of 140 lm/W. Technical values may change depending on the development of LED and equipment. For detailed and accurate lighting values, please visit our website at www.sonled.com Custom length production is available upon request



RRO 1252 SM
Round Ring Optic Lens
Surface Mounted



RRO 1252 SM D2
Round Ring Optic Lens
Surface Mounted

RRO 1252 SU
Round Ring Optic Lens
Suspended



RRO 1252 SU D2
Round Ring Optic Lens
Suspended

Specifications

Profile Section:	w12*h52 mm
Main Body:	Aluminium Profile, static powder painted.
Optic Systems:	Optic Lens (OL)
Lighting Direction:	Direct (D1), Direct/Indirect (D2)
Installation:	Surface Mounted (SM), Suspended (SU)
Beam angle:	Narrow Beam (NB)
Light efficiency:	Avarage 100-160 lm/W
Power:	Low Power (LP), Medium Power (MP),
CCT:	2400~6500K , RGB , RGBW
Control & Dimming:	On/Off, Dali, Push, Triac, 1-10V, Remote, Tunable
CRI:	Ra≥80, Ra≥90
Input voltage:	200-240V AC.

Technical Features & Certifications:

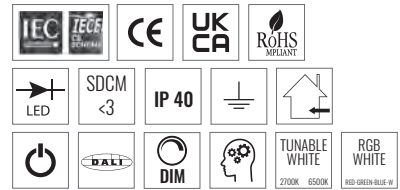

Light Beam

UGR≤11

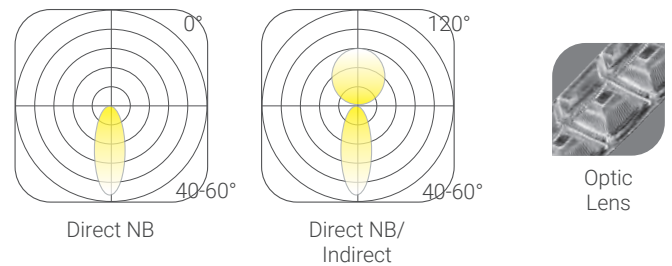

Main Body Colours:

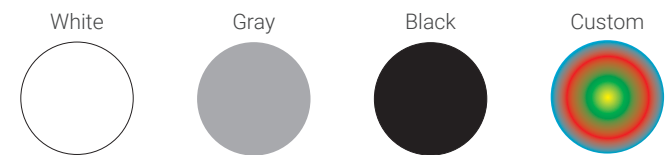

Installation

Surface Mounted



Suspended

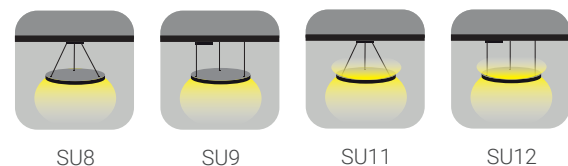

Dimensions

Sections

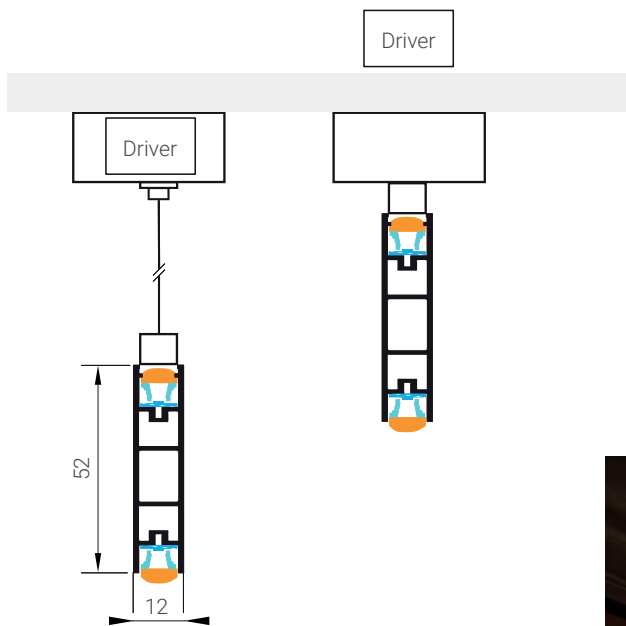

Diameter (Ø) mm		Power (D/I=T) W	Lumen lm	Efficiency lm/W
469	LP	21/21=42	4488	107
	MP	41/21=63	6884	110
644	LP	28/29=58	6163	107
	MP	57/29=86	9453	110
914	LP	40/42=82	8747	107
	MP	80/42=122	13416	110

Standard Reference Conditions:

Luminous flux values are calculated at 4000K CCT with a system efficacy of 140 lm/W.

Technical values may change depending on the development of LED and equipment. For detailed and accurate lighting values, please visit our website at www.sonled.com

Custom length production is available upon request



RRO 3034 SM
Round Ring Optic Lens
 Surface Mounted

RRO 3034 SM D2
Round Ring Optic Lens
 Surface Mounted



RRO 3034 SU
Round Ring Optic Lens
 Suspended

RRO 3034 SU D2
Round Ring Optic Lens
 Suspended

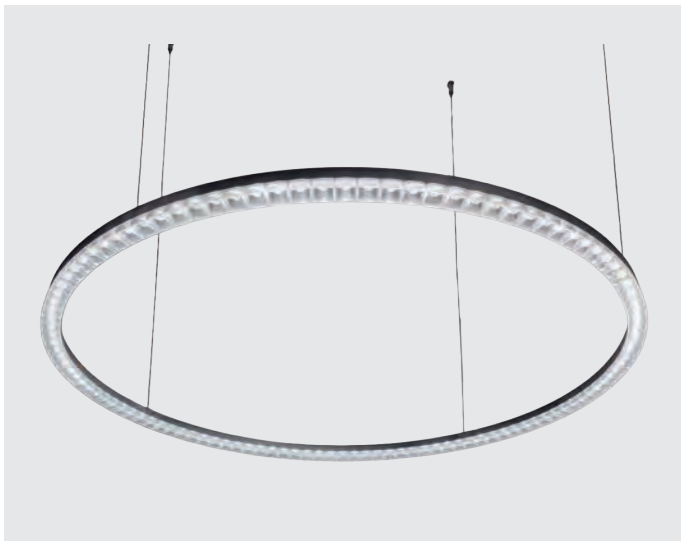

Specifications

- Profile Section:** w30*h34 mm
- Main Body:** Aluminium Profile, static powder painted.
- Optic Systems:** Optic Lens (OL)
- Lighting Direction:** Direct (D1), Direct/Indirect (D2)
- Installation:** Surface Mounted (SM), Suspended (SU)
- Beam angle:** Narrow Beam (NB)
- Light efficiency:** Average 100-160 lm/W
- Power:** Low Power (LP), Medium Power (MP),
- CCT:** 2400~6500K, RGB, RGBW
- Control & Dimming:** On/Off, Dali, Push, Triac, 1-10V, Remote, Tunable
- CRI:** Ra≥80, Ra≥90
- Input voltage:** 200-240V AC.

Technical Features & Certifications:

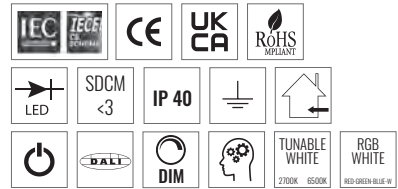

Light Beam

UGR≤15

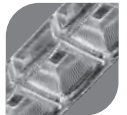
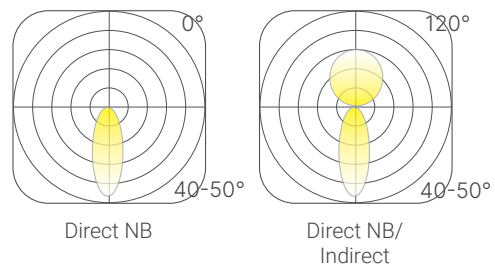

Optic Lens

Main Body Colours:

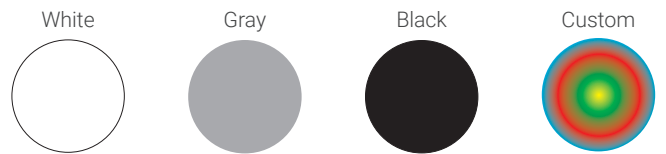

Installation

Surface Mounted

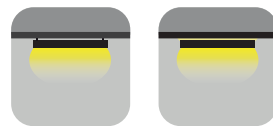

SM2

SM4

Suspended

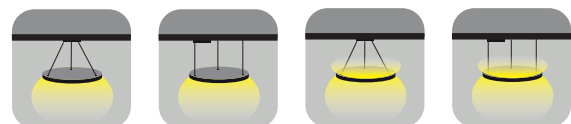

SU8

SU9

SU11

SU12

Dimensions

Sections

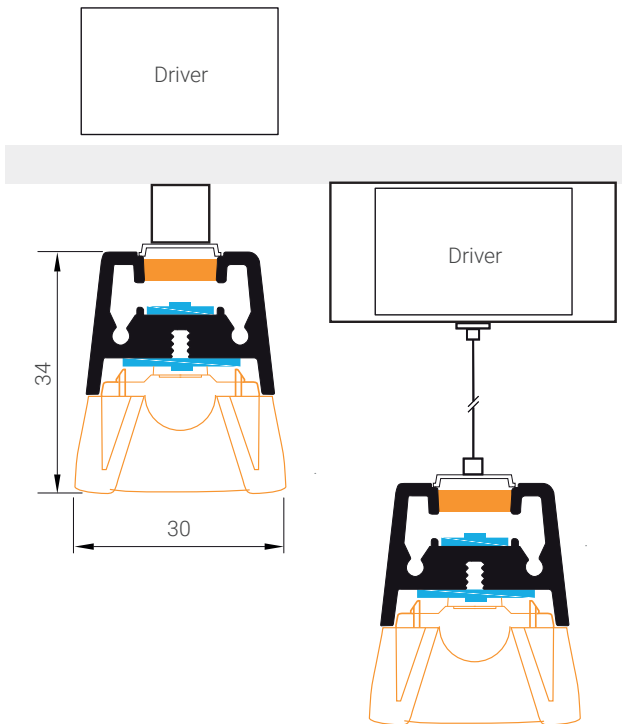

Diameter (Ø) mm		Power (D/I=T) W	Lumen lm	Efficiency lm/W
Ø460	LP	20/21=41	4402	107
	MP	40/21=61	6752	110
Ø650	LP	29/30=58	6221	107
	MP	57/30=87	9541	110
Ø850	LP	37/39=76	8135	107
	MP	75/39=113	12477	110
Ø1050	LP	46/48=94	10049	107
	MP	92/48=140	15412	110
Ø1250	LP	55/57=112	11963	107
	MP	110/57=167	18348	110

Standard Reference Conditions:

Luminous flux values are calculated at 4000K CCT with a system efficacy of 140 lm/W. Technical values may change depending on the development of LED and equipment. For detailed and accurate lighting values, please visit our website at www.sonled.com. Custom length production is available upon request.



RCS H50 RC / RCS H80 RC Round Circle Standard Recessed



For recessed models, the ceiling cutting dimension should be 20 mm less than the product diameter.

RCS H50 SM / RCS H80 SM / RCS H99 SM Round Circle Standard Surface Mounted



RCS H50 SU / RCS H80 SU / RCS H99 SU Round Circle Standard Suspended



Specifications

- Profile Section:** h50 mm, h80 mm, h100 mm,
- Main Body:** Aluminium Profile, Special form cutting steel and aluminium sheet static powder painted.
- Optic Systems:** Opal Diffuser (OD), Opal Prismatic Diffuser (OP), Clear Prismatic Diffuser (PD), Micro Prismatic Diffuser (MP), Clear Prismatic + Opal Diffuser
- Lighting Direction:** Direct (D1)
- Installation:** Recessed (RC), Surface Mounted (SM) Suspended (SU)
- Beam angle:** 120°
- Light efficiency:** Average 100-130 lm/W
- Power:** Medium Power (MP), High Power (LP)
- CCT:** 2400~6500K , RGB , RGBW
- Control & Dimming:** On/Off, Dali, Push, Triac, 1-10V, Remote, Tunable
- CRI:** Ra≥80, Ra≥90
- Input voltage:** 200-240V AC.

Technical Features & Certifications:

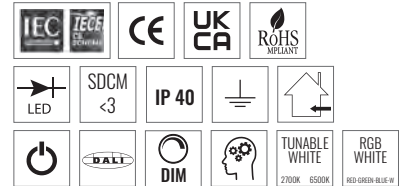

Light Beam

UGR≤19 & UGR≤20

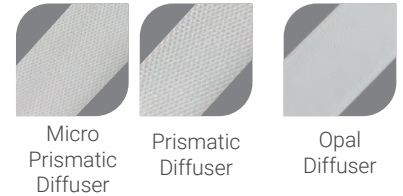
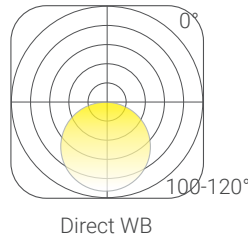

Main Body Colours:

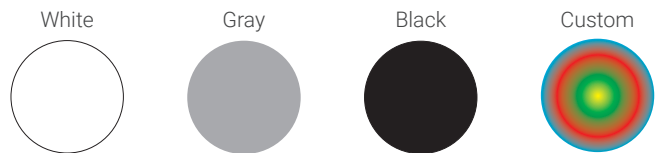

Installation



Dimensions

Sections

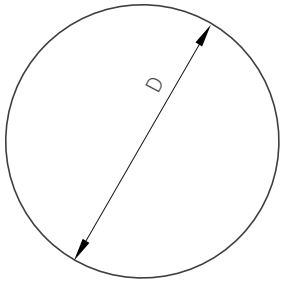

h 50
h 80
h 100

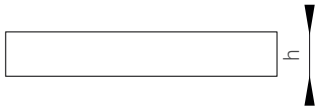

Recessed Profile Sections

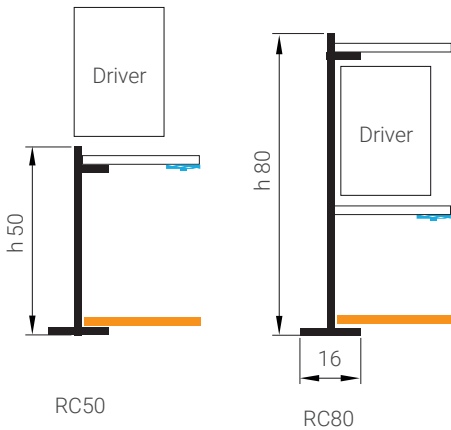

Surface Mounted and Suspended Profile Sections

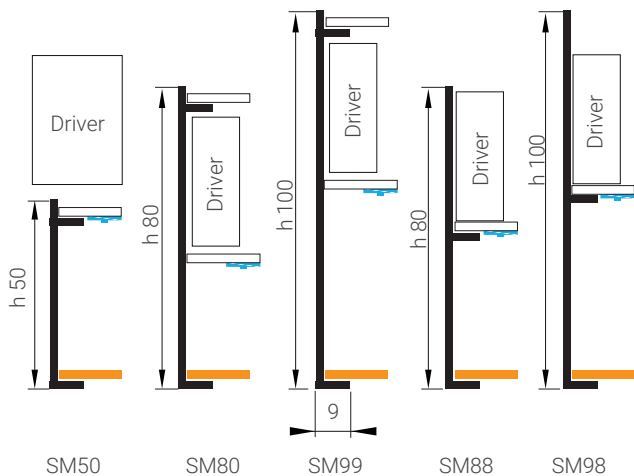

Diameter (Ø) mm		Power W	Lumen lm	Efficiency lm/W
Ø400	MP	32	3136	98
	HP	46	4508	98
Ø600	MP	34	3332	98
	HP	48	4704	98
Ø900	MP	62	6076	98
	HP	94	9212	98
Ø1200	MP	110	10780	98
	HP	152	14896	98

for Opal Diffuser

Diameter (Ø) mm		Power W	Lumen lm	Efficiency lm/W
Ø400	MP	32	3898	122
	HP	46	5603	122
Ø600	MP	34	4141	122
	HP	48	5846	122
Ø900	MP	62	7552	122
	HP	94	11449	122
Ø1200	MP	110	13398	122
	HP	152	18514	122

for Micro Prismatic Diffuser

Standard Reference Conditions:

Luminous flux values are calculated at 4000K CCT with a system efficacy of 140 lm/W. Technical values may change depending on the development of LED and equipment. For detailed and accurate lighting values, please visit our website at www.sonled.com Custom length production is available upon request



RCS H80 SM D2 / RCS H99 SM D2
Round Circle Standard Direct/Indirect
 Surface Mounted



RCS H80 SU D2 / RCS H99 SU D2
Round Circle Standard Direct/Indirect
 Suspended



Specifications

- Profile Section:** h80 mm, h100 mm,
- Main Body:** Aluminium Profile, Special form cutting steel and aluminium sheet static powder painted.
- Optic Systems:** Opal Diffuser (OD), Opal Prismatic Diffuser (OP), Clear Prismatic Diffuser (PD), Micro Prismatic Diffuser (MP), Clear Prismatic + Opal Diffuser
- Lighting Direction:** Direct/Indirect (D2)
- Installation:** Surface Mounted (SM), Suspended (SU)
- Beam angle:** 120°
- Light efficiency:** Avarage 100-130 lm/W
- Power:** Medium Power (MP), High Power (LP)
- CCT:** 2400~6500K , RGB , RGBW
- Control & Dimming:** On/Off, Dali, Push, Triac, 1-10V, Remote, Tunable
- CRI:** Ra≥80, Ra≥90
- Input voltage:** 200-240V AC.

Technical Features & Certifications:

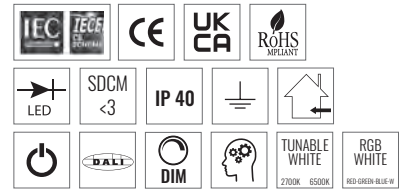

Light Beam

UGR \leq 19 & UGR \leq 20

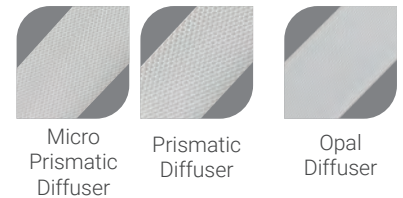
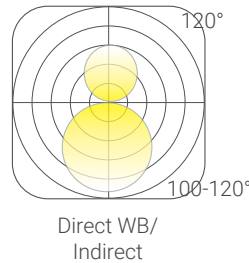

Main Body Colours:

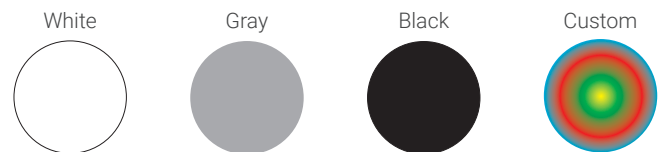

Installation

Surface Mounted



Suspended

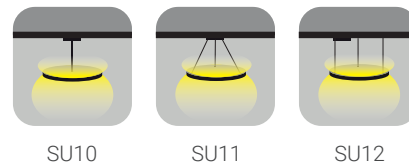

Dimensions

Sections

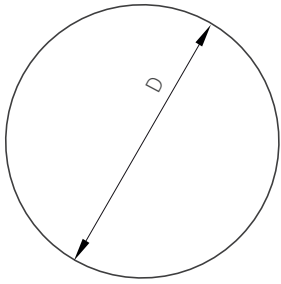

h 80
h 100

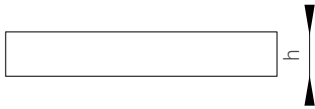

Surface Mounted and Suspended Profile Sections

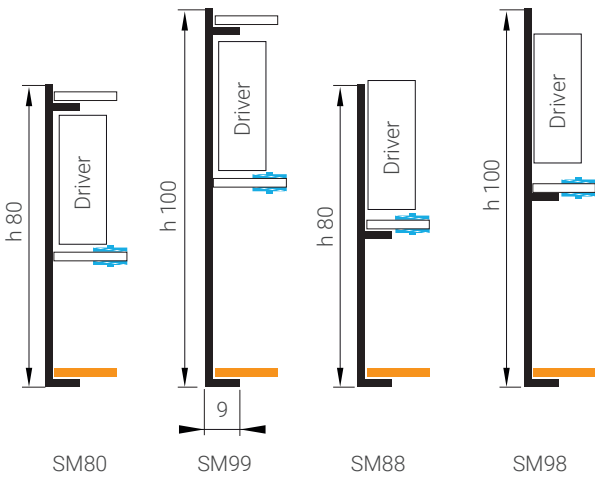

Diameter (Ø) mm		Power (D/I=T) W	Lumen lm	Efficiency lm/W
Ø400	MP	32/18=50	4921	98
	HP	46/18=64	6293	98
Ø600	MP	34/27=61	6009	98
	HP	48/27=75	7381	98
Ø900	MP	62/41=103	10092	98
	HP	94/41=135	13228	98
Ø1200	MP	110/55=165	16134	98
	HP	152/55=207	20250	98

for Opal Diffuser

Diameter (Ø) mm		Power (D/I=T) W	Lumen lm	Efficiency lm/W
Ø400	MP	32/18=50	5682	113
	HP	46/18=64	7388	115
Ø600	MP	34/27=61	6818	113
	HP	48/27=75	8524	115
Ø900	MP	62/41=103	11567	113
	HP	94/41=135	15465	115
Ø1200	MP	110/55=165	18752	113
	HP	152/55=207	23868	115

for Micro Prismatic Diffuser
UGR≤20

Standard Reference Conditions:

Luminous flux values are calculated at 4000K CCT with a system efficacy of 140 lm/W. Technical values may change depending on the development of LED and equipment. For detailed and accurate lighting values, please visit our website at www.sonled.com. Custom length production is available upon request.



RCT H40 RC
Round Circle Trimless
 Recessed



For recessed models, the ceiling cutting dimension should be 20 mm less than the product diameter.

RCT H40 SM / RCT H75 SM
Round Circle Trimless
 Surface Mounted



RCT H40 SU / RCT H75 SU
Round Circle Trimless
 Suspended



Specifications

- Profile Section:** h40 mm, h75 mm,
- Main Body:** Aluminium Profile, Special form cutting steel and aluminium sheet static powder painted.
- Optic Systems:** Opal Diffuser (OD), Opal Prismatic Diffuser (OP), Clear Prismatic Diffuser (PD), Micro Prismatic Diffuser (MP), Clear Prismatic + Opal Diffuser
- Lighting Direction:** Direct (D1)
- Installation:** Recessed (RC), Surface Mounted (SM) Suspended (SU)
- Beam angle:** 120°
- Light efficiency:** Avarage 100-130lm/W
- Power:** Medium Power (MP), High Power (LP)
- CCT:** 2400~6500K , RGB , RGBW
- Control & Dimming:** On/Off, Dali, Push, Triac, 1-10V, Remote, Tunable
- CRI:** Ra≥80, Ra≥90
- Input voltage:** 200-240V AC.

Technical Features & Certifications:

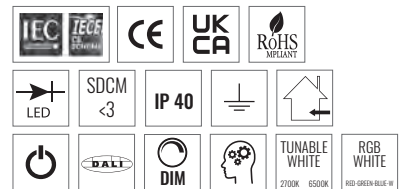

Light Beam

UGR ≤ 19 & UGR ≤ 20

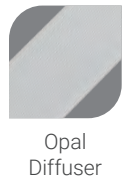
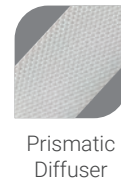
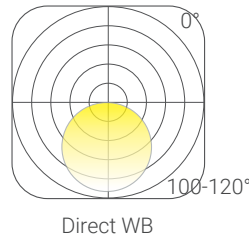

Main Body Colours:

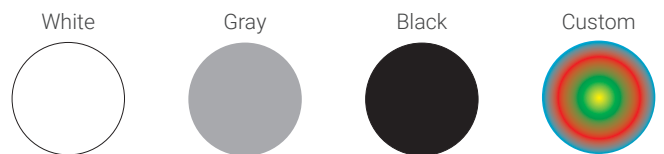

Installation

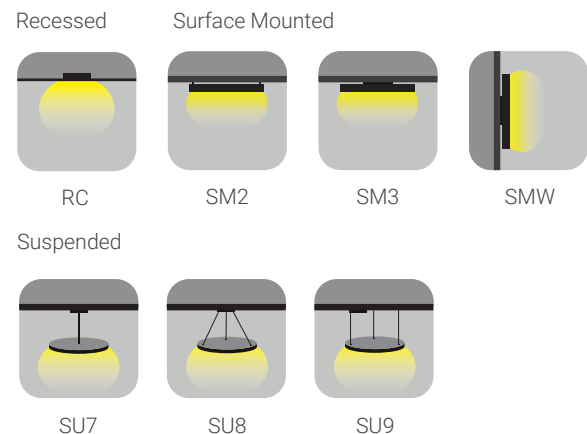

Dimensions

Sections

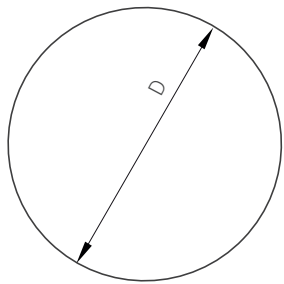

h 40
h 75

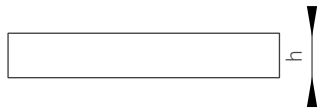

Recessed, Surface Mounted and Suspended Profile Sections

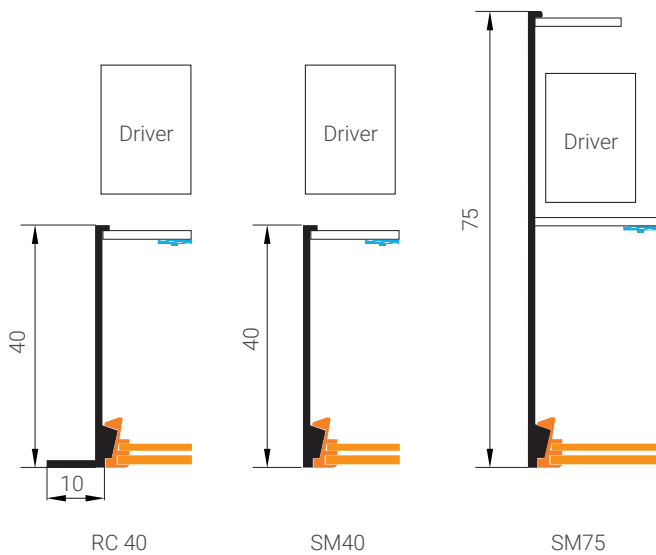

Diameter (Ø) mm		Power W	Lumen lm	Efficiency lm/W
Ø400	MP	32	3136	98
	HP	46	4508	98
Ø600	MP	34	3332	98
	HP	48	4704	98
Ø900	MP	62	6076	98
	HP	94	9212	98
Ø1200	MP	110	10780	98
	HP	152	14896	98

for Opal Diffuser

Diameter (Ø) mm		Power W	Lumen lm	Efficiency lm/W
Ø400	MP	32	2688	84
	HP	46	3864	84
Ø600	MP	34	2856	84
	HP	48	4032	84
Ø900	MP	62	5208	84
	HP	94	7896	84
Ø1200	MP	110	9240	84
	HP	152	12768	84

for Clear Prismatic + Opal Diffuser

Standard Reference Conditions:

Luminous flux values are calculated at 4000K CCT with a system efficacy of 140 lm/W. Technical values may change depending on the development of LED and equipment. For detailed and accurate lighting values, please visit our website at www.sonled.com. Custom length production is available upon request.

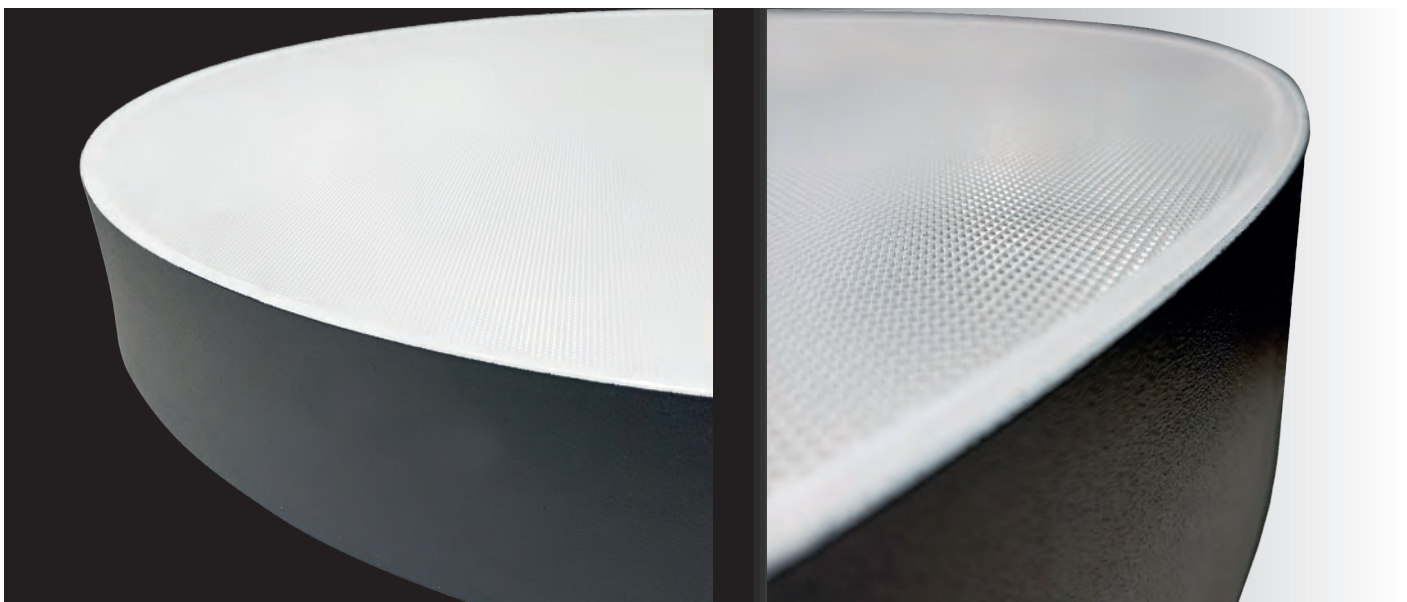

RCT H40 SM D2 / RCT H75 SM D2 Round Circle Trimless Direct/Indirect Surface Mounted



RCT H40 SU D2 / RCT H75 SU D2 Round Circle Trimless Direct/Indirect Suspended



Specifications

Profile Section:	h40 mm, h75 mm,
Main Body:	Aluminium Profile, Special form cutting steel and aluminium sheet static powder painted.
Optic Systems:	Opal Diffuser (OD), Opal Prismatic Diffuser (OP), Clear Prismatic Diffuser (PD), Micro Prismatic Diffuser (MP), Clear Prismatic + Opal Diffuser
Lighting Direction:	Direct/Indirect (D2)
Installation:	Recessed (RC), Surface Mounted (SM) Suspended (SU)
Beam angle:	120°
Light efficiency:	Avarage 100-130lm/W
Power:	Medium Power (MP), High Power (LP)
CCT:	2400~6500K , RGB , RGBW
Control & Dimming:	On/Off, Dali, Push, Triac, 1-10V, Remote, Tunable
CRI:	Ra≥80, Ra≥90
Input voltage:	200-240V AC.

Technical Features & Certifications:



Light Beam

UGR≤19 & UGR≤20

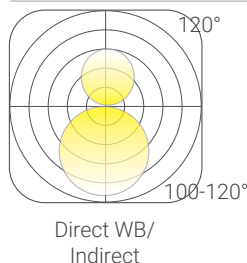

Prismatic Diffuser



Opal Diffuser

Main Body Colours:

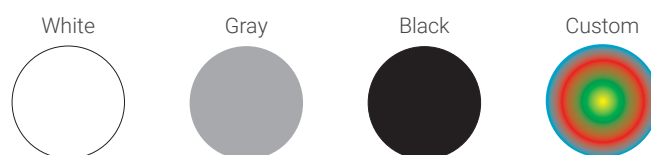

Installation

Surface Mounted



SM4

SM5

SMW2

Suspended



SU10

SU11

SU12

Dimensions

Sections

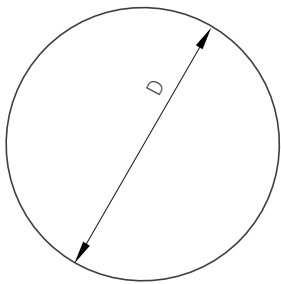

h 40
h 75

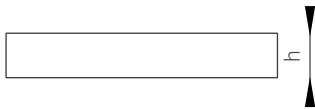

Surface Mounted and Suspended Profile Sections

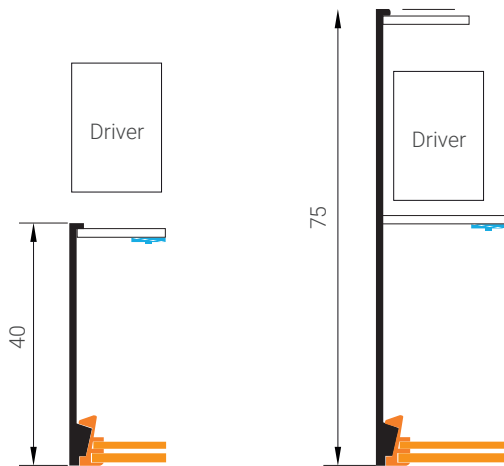

SM 40

SM 75

Diameter (Ø) mm		Power (D/I=T) W	Lumen lm	Efficiency lm/W
Ø400	MP	32/18=50	4921	98
	HP	46/18=64	6293	98
Ø600	MP	34/27=61	6009	98
	HP	48/27=75	7381	98
Ø900	MP	62/41=103	10092	98
	HP	94/41=135	13228	98
Ø1200	MP	110/55=165	16134	98
	HP	152/55=207	20250	98

for Opal Diffuser

Diameter (Ø) mm		Power (D/I=T) W	Lumen lm	Efficiency lm/W
Ø400	MP	32/18=50	4473	88
	HP	46/18=64	5649	88
Ø600	MP	34/27=61	5533	88
	HP	48/27=75	6709	88
Ø900	MP	62/41=103	9224	88
	HP	94/41=135	11912	88
Ø1200	MP	110/55=165	14594	88
	HP	152/55=207	18122	88

for for Clear Prismatic + Opal
Diffuser

Standard Reference Conditions:

Luminous flux values are calculated at 4000K CCT with a system efficacy of 140 lm/W.
Technical values may change depending on the development of LED and equipment. For detailed and accurate lighting values, please visit our website at www.sonled.com
Custom length production is available upon request



RCX H80 SM
Round Circle Textile
 Surface Mounted



RCX H80 SU
Round Circle Textile
 Suspended



Specifications

- Profile Section:** h80 mm
- Main Body:** Aluminium Profile, Special form cutting steel and aluminium sheet static powder painted.
- Optic Systems:** Textile & Back Light Fabric
- Lighting Direction:** Direct (D1)
- Installation:** Surface Mounted (SM) Suspended (SU)
- Beam angle:** 120°
- Light efficiency:** Avarage 100-130lm/W
- Power:** Medium Power (MP), High Power (LP)
- CCT:** 2400~6500K , RGB , RGBW
- Control & Dimming:** On/Off, Dali, Push, Triac, 1-10V, Remote, Tunable
- CRI:** Ra≥80, Ra≥90
- Input voltage:** 200-240V AC.

Technical Features & Certifications:

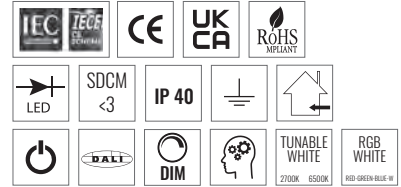

Light Beam

UGR≤20

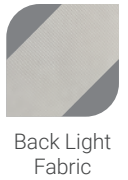
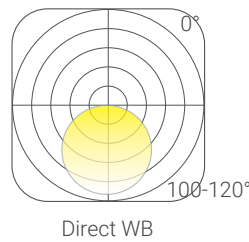

Main Body Colours:

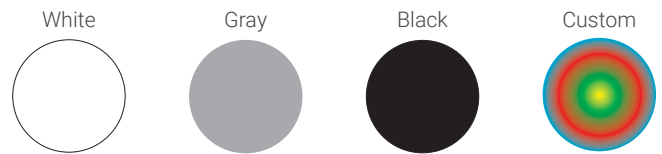

Installation

Surface Mounted



Suspended

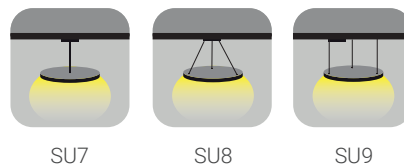

Dimensions

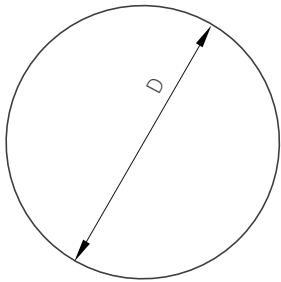

Sections

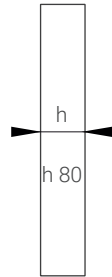

Surface Mounted and Suspended Profile Sections

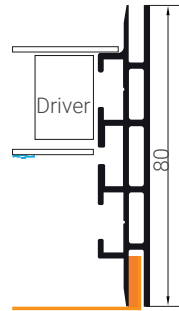

Diameter (Ø) mm		Power W	Lumen lm	Efficiency lm/W
Ø400	MP	32	3136	98
	HP	46	4508	98
Ø600	MP	34	3332	98
	HP	48	4704	98
Ø900	MP	62	6076	98
	HP	94	9212	98
Ø1200	MP	110	10780	98
	HP	152	14896	98
Ø1500	MP	172	16856	98
	HP	238	23324	98
Ø2000	MP	306	29988	98
	HP	422	41356	98

Standard Reference Conditions:

Luminous flux values are calculated at 4000K CCT with a system efficacy of 140 lm/W.

Technical values may change depending on the development of LED and equipment. For detailed and accurate lighting values, please visit our website at www.sonled.com

Custom length production is available upon request



RCA H80 SM
Round Circle Acrylic
 Surface Mounted



RCA H80 SU
Round Circle Acrylic
 Suspended



Specifications

- Profile Section:** h80 mm
- Main Body:** Special form steel and static powder painted.
- Optic Systems:** PMMA Acrylic diffuser (opal 70% - 50%)
- Lighting Direction:** Direct (D1)
- Installation:** Surface Mounted (SM), Suspended (SU)
- Beam angle:** 120°
- Light efficiency:** Average 100-120lm/W
- Power:** Medium Power (MP), High Power (LP)
- CCT:** 2400~6500K, RGB, RGBW
- Control & Dimming:** On/Off, Dali, Push, Triac, 1-10V, Remote, Tunable
- CRI:** Ra≥80, Ra≥90
- Input voltage:** 200-240V AC.

Technical Features & Certifications:

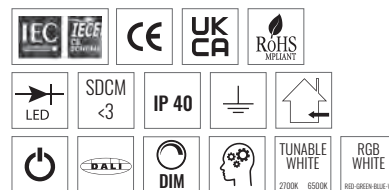

Light Beam

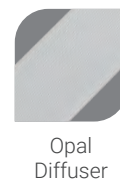
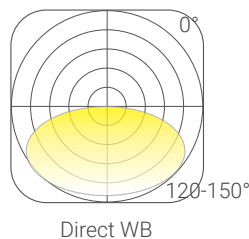

Main Body Colours:

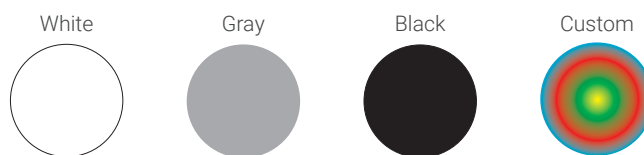

Installation

Surface Mounted



Suspended

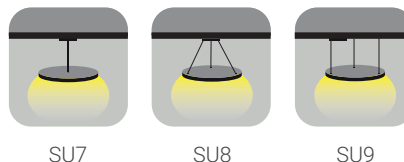

Dimensions

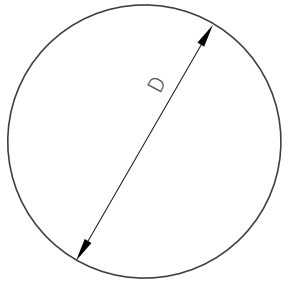

Sections

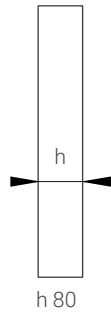

Surface Mounted and Suspended Sections

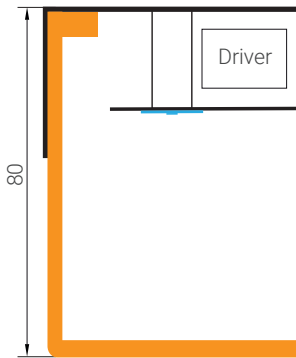

Diameter (Ø) mm		Power W	Lumen lm	Efficiency lm/W
Ø400	MP	32	2688	84
	HP	46	3864	84
Ø600	MP	34	2856	84
	HP	48	4032	84
Ø900	MP	62	5208	84
	HP	94	7896	84
Ø1200	MP	110	9240	84
	HP	152	12768	84

Standard Reference Conditions:

Luminous flux values are calculated at 4000K CCT with a system efficacy of 140 lm/W. Technical values may change depending on the development of LED and equipment. For detailed and accurate lighting values, please visit our website at www.sonled.com. Custom length production is available upon request.







PANELS

Light as a Surface. Space as an Experience.

Panel lighting is no longer limited to ceilings.

In contemporary architectural design, LED panels are used as luminous surfaces – shaping walls, defining backgrounds, and transforming ordinary planes into atmospheric elements.

The SONLED Panels collection is developed for flexible architectural applications. From illuminated bar backdrops to retail shelving highlights, from vertical wall integrations to custom decorative installations, our panel systems adapt beyond traditional use.

Instead of simply providing uniform light, they create depth, contrast, and visual focus. A softly illuminated surface can frame a product, enhance materials, or become a calm luminous background that elevates the entire space.

With refined diffusion, balanced brightness, and clean geometries, our architectural LED panel solutions allow designers to treat light as a material – not just a fixture.

Ceiling or wall.
Background or feature.
Light that builds atmosphere.

PCS H11 RC
Panel Light Corner Standard
 Recessed



PCS H11 SM
Panel Light Corner Standard
 Surface Mounted



PCS H11 SU
Panel Light Corner Standard
 Suspended



Specifications

- Profile Section:** h11 mm
- Main Body:** Aluminium anodized profile or with static powder painted profile, Reflector, Pet and Aluminium sheet.
- Optic Systems:** PMMA Acrylic with galvo laser marking, Opal Diffuser (OD), Opal Prismatic Diffuser (OP), Clear Prismatic Diffuser (PD), Micro Prismatic Diffuser (MP), Clear Prismatic + Opal Diffuser
- Lighting Direction:** Direct (D1)
- Installation:** Recessed (RC), Surface Mounted (SM), Suspended (SU)
- Beam angle:** 120°
- Light efficiency:** Average 100-120lm/W
- Power:** Medium Power (MP), High Power (LP)
- CCT:** 2400~6500K , RGB , RGBW
- Control & Dimming:** On/Off, Dali, Push, Triac, 1-10V, Remote, Tunable
- CRI:** Ra≥80, Ra≥90
- Input voltage:** 200-240V AC.

Technical Features & Certifications:

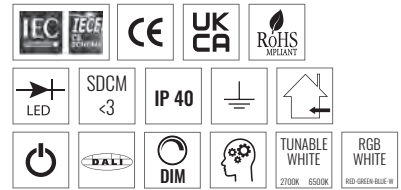

Light Beam

UGR≤19 UGR≤20

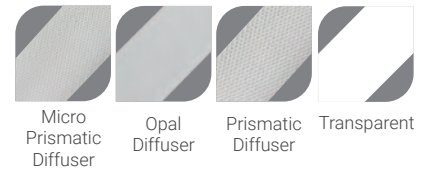
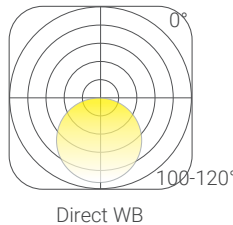

Main Body Colours:

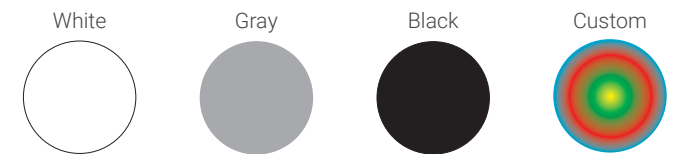

Installation

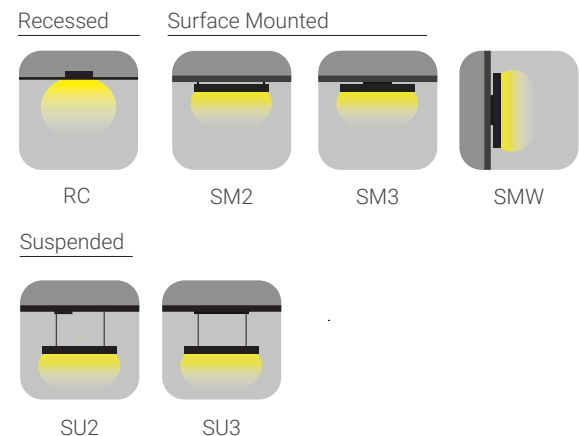

Dimensions

Sections

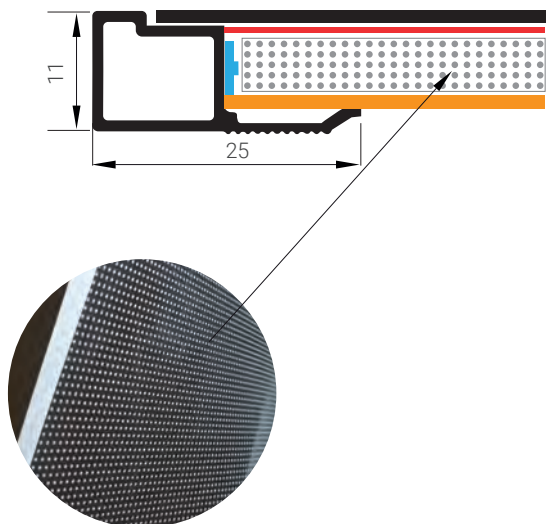

W x L mm		Power W	Lumen lm	Efficiency lm/W
295 x 295	MP	17	1677	98
	HP	25	2428	98
295 x 595	MP	26	2529	98
	HP	37	3663	98
295 x 1195	MP	43	4235	98
	HP	63	6133	98
295 x 1495	MP	52	5087	98
	HP	75	7368	98
295 x 1795	MP	61	5940	98
	HP	88	8602	98
595 x 595	MP	35	3382	98
	HP	50	4898	98
595 x 1195	MP	52	5087	98
	HP	75	7368	98
595 x 1495	MP	61	5940	98
	HP	88	8602	98
595 x 1795	MP	69	6792	98
	HP	100	9837	98
for Opal Diffuser				

W x L mm		Power W	Lumen lm	Efficiency lm/W
295 x 295	MP	17	1437	84
	HP	25	2082	84
295 x 595	MP	26	2168	84
	HP	37	3140	84
295 x 1195	MP	43	3630	84
	HP	63	5257	84
295 x 1495	MP	52	4360	84
	HP	75	6315	84
295 x 1795	MP	61	5091	84
	HP	88	7374	84
595 x 595	MP	35	2899	84
	HP	50	4198	84
595 x 1195	MP	52	4360	84
	HP	75	6315	84
595 x 1495	MP	61	5091	84
	HP	88	7374	84
595 x 1795	MP	69	5922	84
	HP	100	8432	84
for Opal + Clear Prismatic Diffuser, UGR≤19				

W x L mm		Power W	Lumen lm	Efficiency lm/W
295 x 295	MP	17	2156	126
	HP	25	3122	126
295 x 595	MP	26	3252	126
	HP	37	4710	126
295 x 1195	MP	43	5444	126
	HP	63	7885	126
295 x 1495	MP	52	6541	126
	HP	75	9473	126
295 x 1795	MP	61	7637	126
	HP	88	11060	126
595 x 595	MP	35	4348	126
	HP	50	6297	126
595 x 1195	MP	52	6541	126
	HP	75	9473	126
595 x 1495	MP	61	7637	126
	HP	88	11060	126
595 x 1795	MP	69	8733	126
	HP	100	12648	126
for Transparent Diffuser				

Standard Reference Conditions:

Luminous flux values are calculated at 4000K CCT with a system efficacy of 140 lm/W.

Technical values may change depending on the development of LED and equipment. For detailed and accurate lighting values, please visit our website at www.sonled.com

Custom length production is available upon request

PCS H11 SM D2
Panel Light Corner Standard Direct/Indirect
 Surface Mounte



PCS H11 SU D2
Panel Light Corner Standard Direct/Indirect
 Suspended



Specifications

- Profile Section:** h11 mm
- Main Body:** Aluminium anodized profile or with static powder painted profile, Reflector, Pet and Aluminium sheet.
- Optic Systems:** PMMA Acrylic with galvo laser marking, Opal Diffuser (OD), Opal Prismatic Diffuser (OP), Clear Prismatic Diffuser (PD), Micro Prismatic Diffuser (MP), Clear Prismatic + Opal Diffuser
- Lighting Direction:** Direct/Indirect (D2)
- Installation:** Surface Mounted (SM), Suspended (SU)
- Beam angle:** 120°
- Light efficiency:** Avarage 100-120lm/W
- Power:** Medium Power (MP), High Power (LP)
- CCT:** 2400~6500K , RGB , RGBW
- Control & Dimming:** On/Off, Dali, Push, Triac, 1-10V, Remote, Tunable
- CRI:** Ra≥80, Ra≥90
- Input voltage:** 200-240V AC.

Technical Features & Certifications:

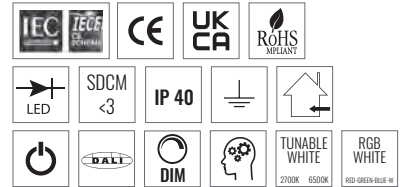

Light Beam

UGR≤19 UGR≤20

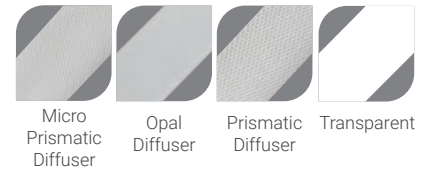
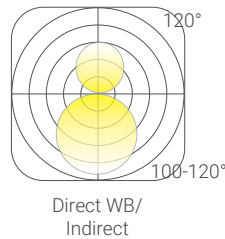

Main Body Colours:

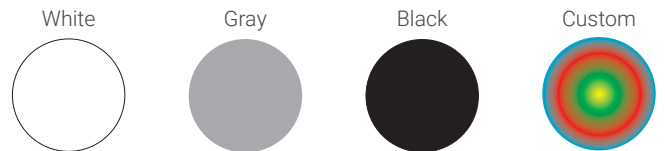

Installation

Surface Mounted

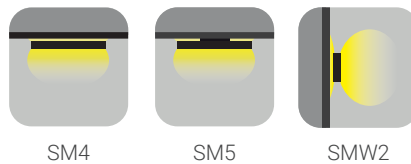

Suspended

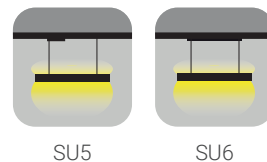

Dimensions

Sections

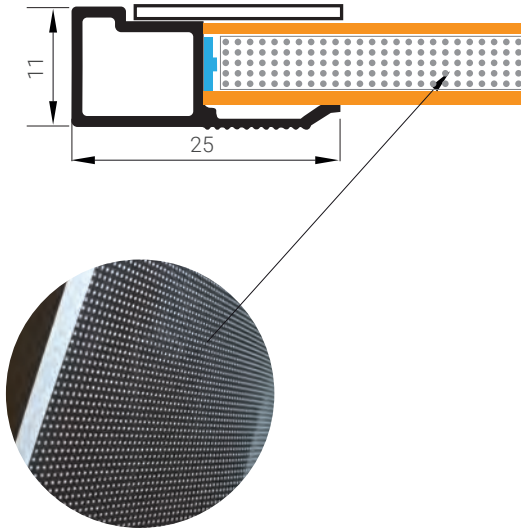

W x L mm		Power W	Lumen (D/I=T) lm	Efficiency lm/W
295 x 295	MP	17	1294/862=2156	126
	HP	25	1873/1249=3122	126
295 x 595	MP	26	1951/1301=3252	126
	HP	37	2826/1884=4710	126
295 x 1195	MP	43	3267/2178=5444	126
	HP	63	4731/3154=7885	126
295 x 1495	MP	52	3924/2616=6541	126
	HP	75	5684/3789=9473	126
295 x 1795	MP	61	4582/3055=7637	126
	HP	88	6636/4424=11060	126
595 x 595	MP	35	2609/1739=4348	126
	HP	50	3778/2519=6297	126
595 x 1195	MP	52	3924/2616=6541	126
	HP	75	5684/3789=9473	126
595 x 1495	MP	61	4582/3055=7637	126
	HP	88	6636/4424=11060	126
595 x 1795	MP	69	5240/3493=8733	126
	HP	100	7589/5059=12648	126
for Transparent Diffuser				

Standard Reference Conditions:

Luminous flux values are calculated at 4000K CCT with a system efficacy of 140 lm/W.

Technical values may change depending on the development of LED and equipment. For detailed and accurate lighting values, please visit our website at www.sonled.com

Custom length production is available upon request

W x L mm		Power W	Lumen (D/I=T) lm	Efficiency lm/W
295 x 295	MP	17	1006/671=1677	98
	HP	25	1457/971=2428	98
295 x 595	MP	26	1518/1012=2529	98
	HP	37	2198/1465=3663	98
295 x 1195	MP	43	2541/1694=4235	98
	HP	63	3680/2453=6133	98
295 x 1495	MP	52	3052/2035=5087	98
	HP	75	4421/2947=7368	98
295 x 1795	MP	61	3564/2376=5940	98
	HP	88	5161/3441=8602	98
595 x 595	MP	35	2029/1353=3382	98
	HP	50	2939/1959=4898	98
595 x 1195	MP	52	3052/2035=5087	98
	HP	75	4421/2947=7368	98
595 x 1495	MP	61	3564/2376=5940	98
	HP	88	5161/3441=8602	98
595 x 1795	MP	69	4075/2717=6792	98
	HP	100	5901/3935=9837	98
for Opal Diffuser				

W x L mm		Power W	Lumen (D/I=T) lm	Efficiency lm/W
295 x 295	MP	17	862/575=1437	84
	HP	25	1249/833=2082	84
295 x 595	MP	26	1301/867=2168	84
	HP	37	1884/1256=3140	84
295 x 1195	MP	43	2178/1452=3630	84
	HP	63	3154/2103=5257	84
295 x 1495	MP	52	2616/1744=4360	84
	HP	75	3789/2526=6315	84
295 x 1795	MP	61	3055/2036=5091	84
	HP	88	4424/2949=7374	84
595 x 595	MP	35	1739/1160=2899	84
	HP	50	2519/1679=4198	84
595 x 1195	MP	52	2616/1744=4360	84
	HP	75	3789/2526=6315	84
595 x 1495	MP	61	3055/2036=5091	84
	HP	88	4424/2949=7374	84
595 x 1795	MP	69	3493/2329=5822	84
	HP	100	5059/3373=8432	84
for Opal + Clear Prismatic Diffuser, UGR≤19				

PRS H11 SM
Panel Light Round Standard
 Surface Mounted



PRS H11 SU
Panel Light Round Standard
 Suspended



Specifications

- Profile Section:** h11 mm
- Main Body:** Aluminium + Steel Profile with static powder painted, Reflector, Diffuser instead of Aluminium sheet for Up lighting.
- Optic Systems:** PMMA Acrylic with galvo laser marking, Opal Diffuser (OD), Opal Prismatic Diffuser (OP), Clear Prismatic Diffuser (PD), Micro Prismatic Diffuser (MP), Clear Prismatic + Opal Diffuser
- Lighting Direction:** Direct (D1)
- Installation:** Surface Mounted (SM), Suspended (SU)
- Beam angle:** 120°
- Light efficiency:** Average 100-120lm/W
- Power:** Medium Power (MP), High Power (LP)
- CCT:** 2400~6500K, RGB, RGBW
- Control & Dimming:** On/Off, Dali, Push, Triac, 1-10V, Remote, Tunable
- CRI:** Ra≥80, Ra≥90
- Input voltage:** 200-240V AC.

Technical Features & Certifications:

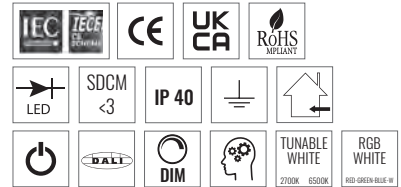

Light Beam

UGR≤19 UGR≤20

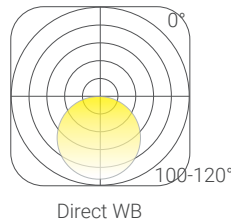

Main Body Colours:

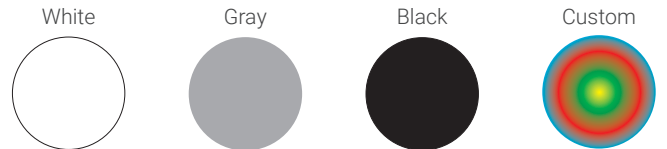

Installation

Surface Mounted



SM2

SM3

Suspended



SU7

SU8

SU9

Dimensions

Sections

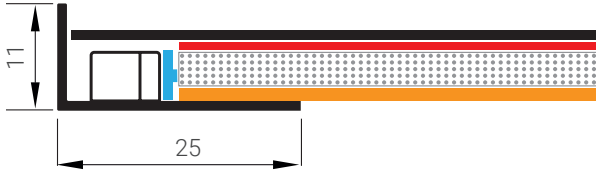

Diameter (Ø) mm		Power W	Lumen lm	Efficiency lm/W
400	MP	18	1785	98
	HP	26	2585	98
600	MP	27	2677	98
	HP	40	3877	98
900	MP	41	4016	98
	HP	59	5816	98
for Opal Diffuser				

Diameter (Ø) mm		Power W	Lumen lm	Efficiency lm/W
400	MP	18	2295	126
	HP	26	3323	126
600	MP	27	3442	126
	HP	40	4985	126
900	MP	41	5163	126
	HP	59	7478	126
for Transparent Diffuser				

Diameter (Ø) mm		Power W	Lumen lm	Efficiency lm/W
400	MP	18	1530	84
	HP	26	2216	84
600	MP	27	2295	84
	HP	40	3323	84
900	MP	41	3442	84
	HP	59	4985	84
for Opal + Clear Prismatic Diffuser, UGR≤19				

Standard Reference Conditions:

Luminous flux values are calculated at 4000K CCT with a system efficacy of 140 lm/W.

Technical values may change depending on the development of LED and equipment. For detailed and accurate lighting values, please visit our website at www.sonled.com

Custom length production is available upon request



PRS H11 SM D2
Panel Light Round Standard Direct/Indirect
 Surface Mounted



PRS H11 SU D2
Panel Light Round Standard Direct/Indirect
 Suspended



Specifications

- Profile Section:** h11 mm
- Main Body:** Aluminium + Steel Profile with static powder painted, Reflector, Diffuser instead of Aluminium sheet for Up lighting.
- Optic Systems:** PMMA Acrylic with galvo laser marking, Opal Diffuser (OD), Opal Prismatic Diffuser (OP), Clear Prismatic Diffuser (PD), Micro Prismatic Diffuser (MP), Clear Prismatic + Opal Diffuser
- Lighting Direction:** Direct/Indirect (D2)
- Installation:** Surface Mounted (SM), Suspended (SU)
- Beam angle:** 120°
- Light efficiency:** Average 100-120lm/W
- Power:** Medium Power (MP), High Power (LP)
- CCT:** 2400~6500K , RGB , RGBW
- Control & Dimming:** On/Off, Dali, Push, Triac, 1-10V, Remote, Tunable
- CRI:** Ra≥80, Ra≥90
- Input voltage:** 200-240V AC.

Technical Features & Certifications:

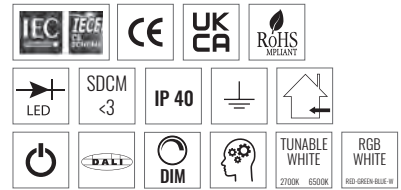

Light Beam

UGR≤19 UGR≤20

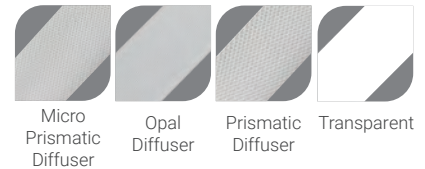
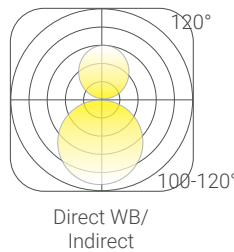

Main Body Colours:

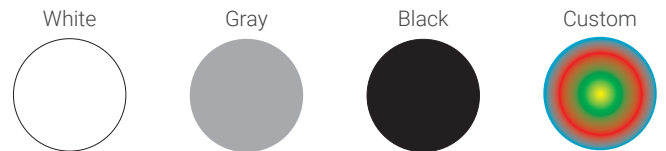

Installation

Surface Mounted

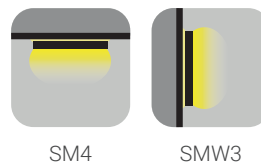

Suspended

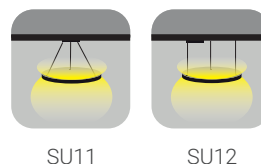

Dimensions

Sections

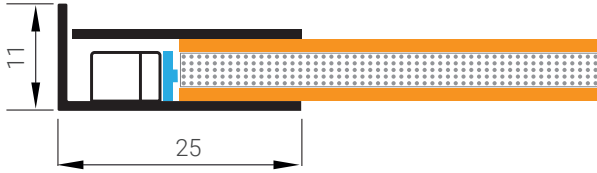

Diameter (Ø) mm	Power W	Lumen (D/I=T) lm	Efficiency lm/W	
400	MP	18	1071/714=1785	98
	HP	26	1551/1034=2585	98
600	MP	27	1606/1071=2677	98
	HP	40	2326/1551=3877	98
900	MP	41	2409/1606=4016	98
	HP	59	3490/2326=5816	98
for Opal Diffuser				

Diameter (Ø) mm	Power W	Lumen (D/I=T) lm	Efficiency lm/W	
400	MP	18	1377/918=2295	126
	HP	26	1994/1329=3323	126
600	MP	27	2065/1377=3442	126
	HP	40	2991/1994=4985	126
900	MP	41	3098/2065=5163	126
	HP	59	4487/2991=7478	126
for Transparent Diffuser				

Diameter (Ø) mm	Power W	Lumen (D/I=T) lm	Efficiency lm/W	
400	MP	18	918/612=1530	84
	HP	26	1329/886=2216	84
600	MP	27	1377/918=2295	84
	HP	40	1994/1329=3323	84
900	MP	41	2065/1377=3442	84
	HP	59	2991/1994=4985	84
for Opal + Clear Prismatic Diffuser, UGR≤19				

Standard Reference Conditions:

Luminous flux values are calculated at 4000K CCT with a system efficacy of 140 lm/W.

Technical values may change depending on the development of LED and equipment. For detailed and accurate lighting values, please visit our website at www.sonled.com

Custom length production is available upon request



PCF H16 SM / PCF H20 SM
Panel Light Corner Frameless
 Surface Mounted

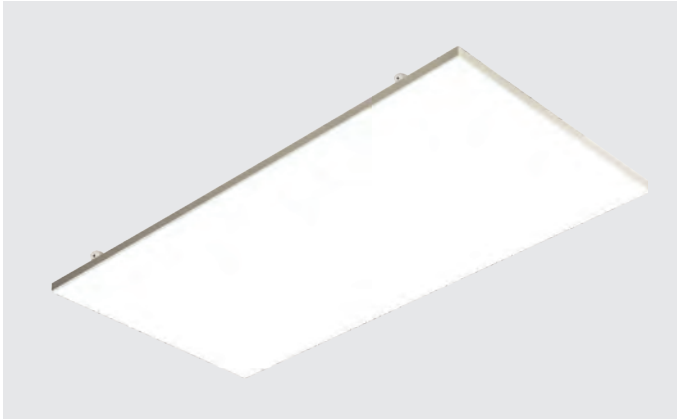

PCF H16 SU / PCF H20 SU
Panel Light Corner Frameless
 Suspended

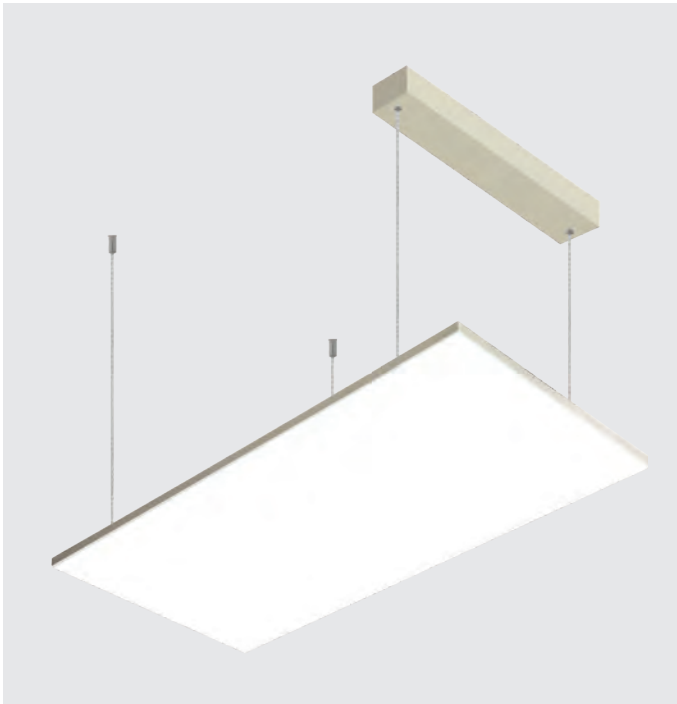

Specifications

- Profile Section:** h16 - h20 mm
- Main Body:** Aluminium anodized profile or with static powder painted profile, Reflector, Pet and Aluminium sheet.
- Optic Systems:** PMMA Acrylic with galvo laser marking, Opal Diffuser (OD).
- Lighting Direction:** Direct (D1)
- Installation:** Surface Mounted (SM), Suspended (SU)
- Beam angle:** 120°
- Light efficiency:** Avarage 100-120lm/W
- Power:** Medium Power (MP), High Power (LP)
- CCT:** 2400~6500K , RGB , RGBW
- Control & Dimming:** On/Off, Dali, Push, Triac, 1-10V, Remote, Tunable
- CRI:** Ra≥80, Ra≥90
- Input voltage:** 200-240V AC.

Technical Features & Certifications:

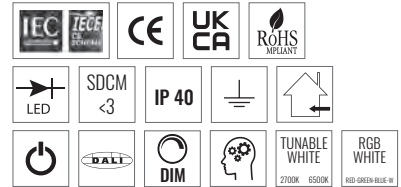

Light Beam

UGR≤20

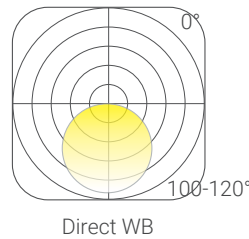

Opal Diffuser

Main Body Colours:

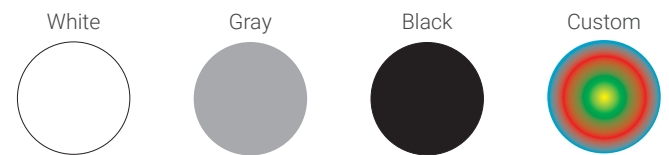

Installation

Surface Mounted



Suspended

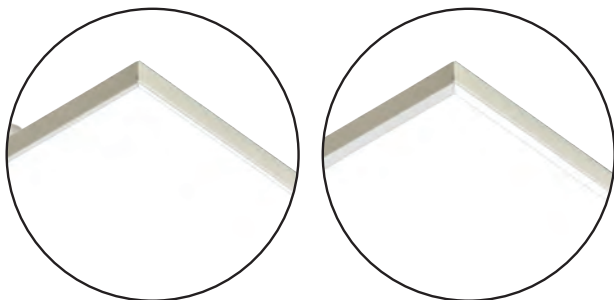
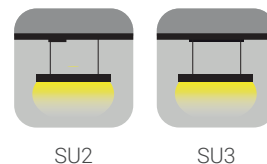

Dimensions

Sections

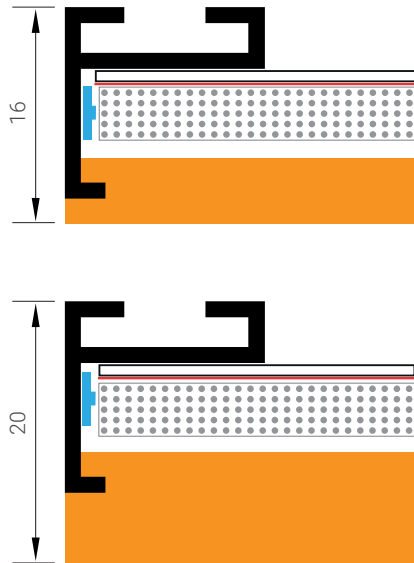

Thickness H mm	Power W / m	Lumen lm / m	Efficiency lm/W
16	14,5	1421	98
	21	2058	98
20	14,5	1015	70
	21	1470	70
for Opal Diffuser (Matte Surface or Glossy Surface)			

Values shown are per linear meter and may vary depending on the panel dimensions and project specifications.



W x L x H mm		Power W	Lumen lm	Efficiency lm/W
295 x 295 x 16	MP	17	1677	98
	HP	25	2428	98
295 x 595 x 16	MP	26	2529	98
	HP	37	3663	98
295 x 1195 x 16	MP	43	4235	98
	HP	63	6133	98
295 x 1495 x 16	MP	52	5087	98
	HP	75	7368	98
295 x 1795 x 16	MP	61	5940	98
	HP	88	8602	98
595 x 595 x 16	MP	35	3388	98
	HP	50	4898	98
595 x 1195 x 16	MP	52	5087	98
	HP	75	7368	98
595 x 1495 x 16	MP	61	5940	98
	HP	88	8602	98
595 x 1795 x 16	MP	69	6792	98
	HP	100	9837	98
for Opal Diffuser (Matte Surface or Glossy Surface)				

W x L x H mm		Power W	Lumen lm	Efficiency lm/W
295 x 295 x 20	MP	17	1198	70
	HP	25	1735	70
295 x 595 x 20	MP	26	1807	70
	HP	37	2617	70
295 x 1195 x 20	MP	43	3025	70
	HP	63	4381	70
295 x 1495 x 20	MP	52	3634	70
	HP	75	5263	70
295 x 1795 x 20	MP	61	4243	70
	HP	88	6145	70
595 x 595 x 20	MP	35	2416	70
	HP	50	3499	70
595 x 1195 x 20	MP	52	3634	70
	HP	75	5263	70
595 x 1495 x 20	MP	61	4243	70
	HP	88	6154	70
595 x 1795 x 20	MP	69	4852	70
	HP	100	7027	70
for Opal Diffuser (Matte Surface or Glossy Surface)				

Standard Reference Conditions:
Luminous flux values are calculated at 4000K CCT with a system efficacy of 140 lm/W.
Technical values may change depending on the development of LED and equipment. For detailed and accurate lighting values, please visit our website at www.sonled.com
Custom length production is available upon request

PCT H08 SM / PCT H11 SM / PCT H13 SM Panel Light Corner Thin Surface Mounted

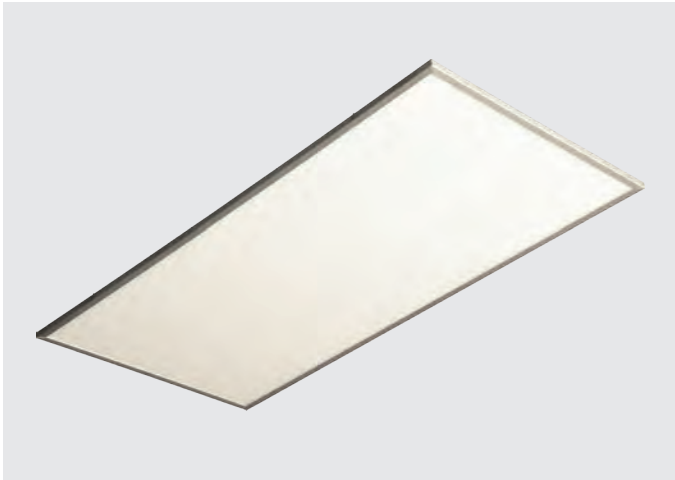

Specifications

- Profile Section:** h8 mm, h11 mm, h13 mm
- Main Body:** Aluminium anodized profile or with static powder painted profile, Reflector, Pet and Aluminium sheet.
- Optic Systems:** PMMA Acrylic with galvo laser marking, Opal Diffuser (OD), Opal Prismatic Diffuser (OP), Clear Prismatic Diffuser (PD), Micro Prismatic Diffuser (MP), Clear Prismatic + Opal Diffuser
- Lighting Direction:** Direct (D1)
- Installation:** Surface Mounted (SM),
- Beam angle:** 120°
- Light efficiency:** Average 100-120lm/W
- Power:** Medium Power (MP), High Power (LP)
- CCT:** 2400~6500K, RGB, RGBW
- Control & Dimming:** On/Off, Dali, Push, Triac, 1-10V, Remote, Tunable
- CRI:** Ra≥80, Ra≥90
- Input voltage:** 200-240V AC.

Technical Features & Certifications:

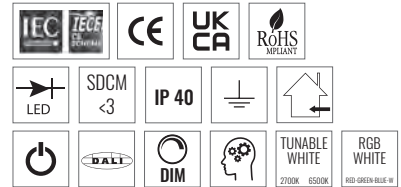

Light Beam

UGR≤19 UGR≤20

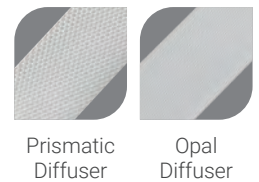
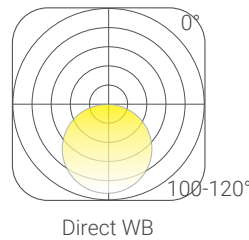

Main Body Colours:

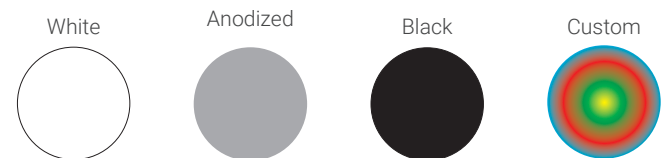

Installation

Surface Mounted



Dimensions

Sections

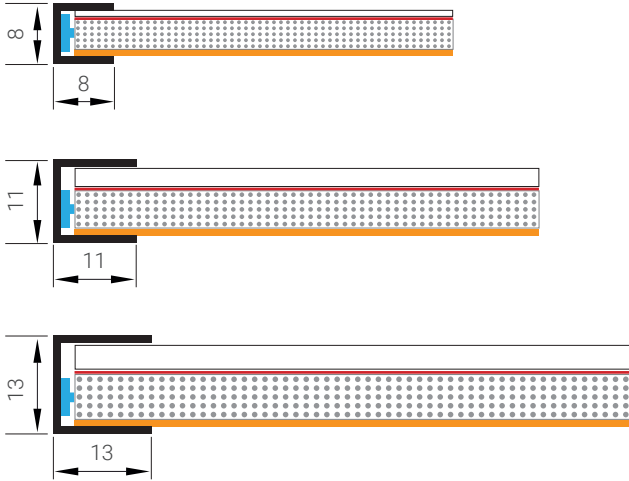

- & different solutions for sections

Power W / m	Lumen lm / m	Efficiency lm/W
14,5	1421	98
21	2058	98

for Opal Diffuser
(Matte Surface or Glossy Surface)

Values shown are per linear meter and may vary depending on the panel dimensions and project specifications.

W x L mm		Power W	Lumen lm	Efficiency lm/W
295 x 295	MP	17	1677	98
	HP	25	2428	98
295 x 595	MP	26	2529	98
	HP	37	3663	98
295 x 1195	MP	43	4235	98
	HP	63	6133	98
295 x 1495	MP	52	5087	98
	HP	75	7368	98
295 x 1795	MP	61	5940	98
	HP	88	8602	98
595 x 595	MP	35	3382	98
	HP	50	4898	98
595 x 1195	MP	52	5087	98
	HP	75	7368	98
595 x 1495	MP	61	5940	98
	HP	88	8602	98
595 x 1795	MP	69	6792	98
	HP	100	9837	98
				for Opal Diffuser

Standard Reference Conditions:

Luminous flux values are calculated at 4000K CCT with a system efficacy of 140 lm/W.

Technical values may change depending on the development of LED and equipment. For detailed and accurate lighting values, please visit our website at www.sonled.com

Custom length production is available upon request



PCX H15 SM / PCX H30 SM
Panel Light Corner Textile
 Surface Mounted

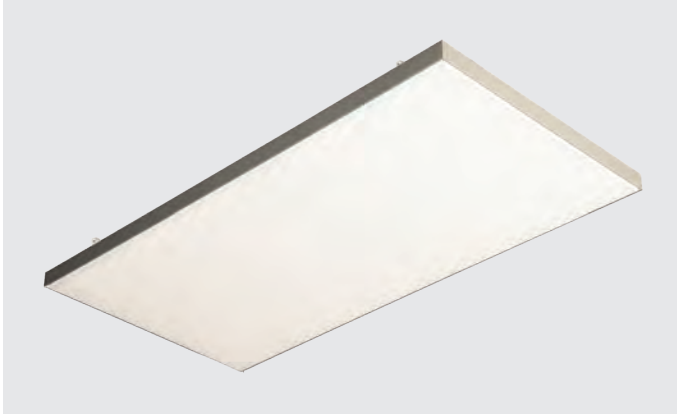

PCX H15 SU / PCX H30 SU
Panel Light Corner Textile
 Suspended



Specifications

- Profile Section:** h15 mm, h30 mm
- Main Body:** Aluminium anodized profile or with static powder painted profile, Reflector, Pet and Aluminium sheet.
- Optic Systems:** Textile & Back Light Fabric
- Lighting Direction:** Direct (D1)
- Installation:** Surface Mounted (SM), Suspended (SU)
- Beam angle:** 120°
- Light efficiency:** Avarage 100-120lm/W
- Power:** Medium Power (MP), High Power (LP)
- CCT:** 2400~6500K , RGB , RGBW
- Control & Dimming:** On/Off, Dali, Push, Triac, 1-10V, Remote, Tunable
- CRI:** Ra≥80, Ra≥90
- Input voltage:** 200-240V AC.

Technical Features & Certifications:

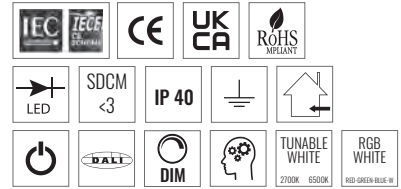

Light Beam

UGR≤20

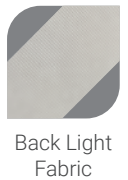
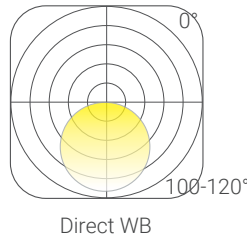

Main Body Colours:

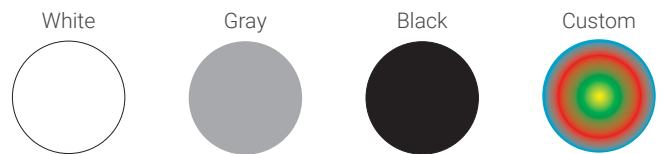

Installation

Surface Mounted



Suspended

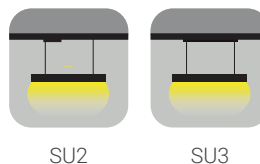

Dimensions

Sections

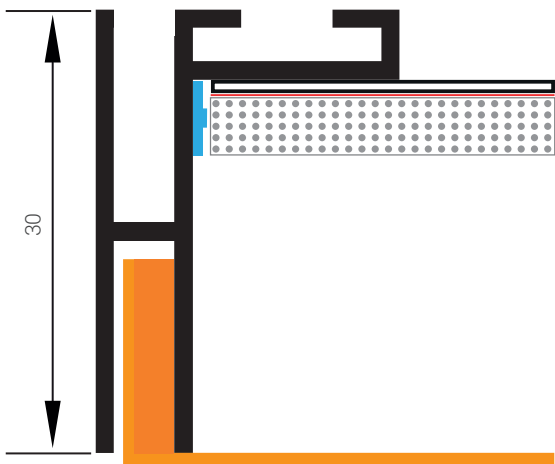
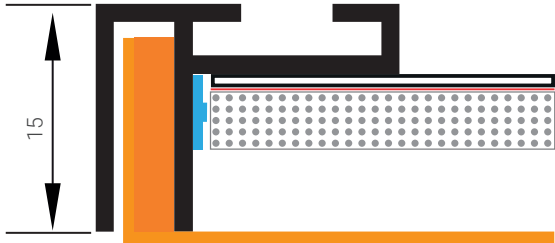

W x L mm		Power W	Lumen lm	Efficiency lm/W
295 x 295	MP	17	1677	98
	HP	25	2428	98
295 x 595	MP	26	2529	98
	HP	37	3663	98
295 x 1195	MP	43	4235	98
	HP	63	6133	98
295 x 1495	MP	52	5087	98
	HP	75	7368	98
295 x 1795	MP	61	5940	98
	HP	88	8602	98
595 x 595	MP	35	3382	98
	HP	50	4898	98
595 x 1195	MP	52	5087	98
	HP	75	7368	98
595 x 1495	MP	61	5940	98
	HP	88	8602	98
595 x 1795	MP	69	6792	98
	HP	100	9837	98
for Opal Diffuser				

Standard Reference Conditions:
 Luminous flux values are calculated at 4000K CCT with a system efficacy of 140 lm/W.
 Technical values may change depending on the development of LED and equipment. For detailed and accurate lighting values, please visit our website at www.sonled.com
 Custom length production is available upon request



PLEC TX SM D2 Panel Light Corner Textile Direct/Indirect Surface Mounted

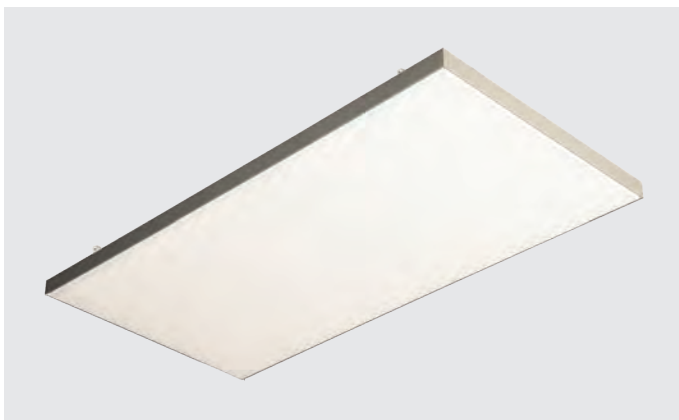

PLEC TX SU D2 Panel Light Corner Textile Direct/Indirect Suspended



Specifications

Profile Section:	h30 mm
Main Body:	Aluminium anodized profile or with static powder painted profile, Reflector, Pet and Aluminium sheet.
Optic Systems:	Textile & Back Light Fabric
Lighting Direction:	Direct/Indirect (D2)
Installation:	Surface Mounted (SM), Suspended (SU)
Beam angle:	120°
Light efficiency:	Avarage 100-120lm/W
Power:	Medium Power (MP), High Power (LP)
CCT:	2400~6500K , RGB , RGBW
Control & Dimming:	On/Off, Dali, Push, Triac, 1-10V, Remote, Tunable
CRI:	Ra≥80, Ra≥90
Input voltage:	200-240V AC.

Technical Features & Certifications:

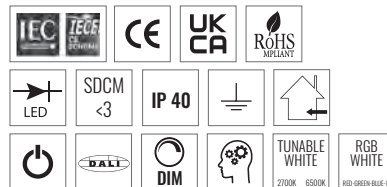

Light Beam

UGR≤20

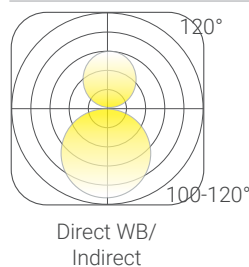

Back Light Fabric

Main Body Colours:

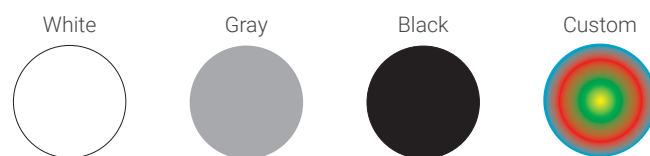

Installation

Surface Mounted

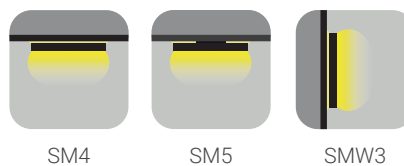

Suspended

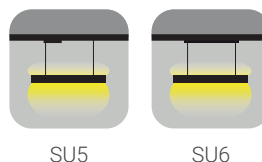

Dimensions

Sections

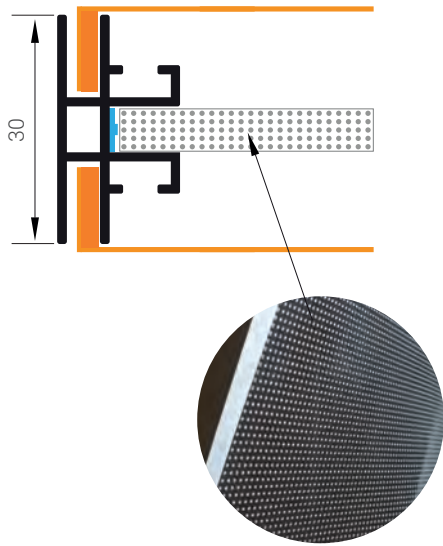

Standard Reference Conditions:
 Luminous flux values are calculated at 4000K CCT with a system efficacy of 140 lm/W.
 Technical values may change depending on the development of LED and equipment. For detailed and accurate lighting values, please visit our website at www.sonled.com
 Custom length production is available upon request

W x L mm		Power W	Lumen (D/I=T) lm	Efficiency lm/W
295 x 295	MP	17	1006/671=1677	98
	HP	25	1457/971=2428	98
295 x 595	MP	26	1518/1012=2529	98
	HP	37	2198/1465=3663	98
295 x 1195	MP	43	2541/1694=4235	98
	HP	63	3680/2453=6133	98
295 x 1495	MP	52	3052/2035=5087	98
	HP	75	4421/2947=7368	98
295 x 1795	MP	61	3564/2376=5940	98
	HP	88	5161/3441=8602	98
595 x 595	MP	35	2029/1353=3382	98
	HP	50	2939/1959=4898	98
595 x 1195	MP	52	3052/2035=5087	98
	HP	75	4421/2947=7368	98
595 x 1495	MP	61	3564/2376=5940	98
	HP	88	5161/3441=8602	98
595 x 1795	MP	69	4075/2717=6792	98
	HP	100	5901/3935=9837	98
			for Opal Diffuser	



PDS SM
Panel Light Design Sun
 Surface Mounted



PDS SU
Panel Light Design Sun
 Suspended

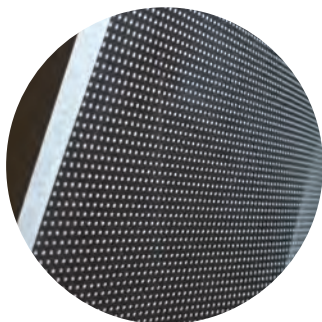

Specifications

- Profile Section:** h11 mm
- Main Body:** Aluminium + Steel Profile with static powder painted, Reflector, Difusser instead of Aluminium sheet for Up lighting.
- Optic Systems:** PMMA Acrylic with galvo laser marking, Opal Diffuser (OD), Opal Prismatic Diffuser (OP), Clear Prismatic Diffuser (PD), Micro Prismatic Diffuser (MP), Clear Prismatic + Opal Diffuser
- Lighting Direction:** Direct (D1)
- Installation:** Surface Mounted (SM), Suspended (SU)
- Beam angle:** 120°
- Light efficiency:** Avarage 100-120lm/W
- Power:** Medium Power (MP), High Power (LP)
- CCT:** 2400~6500K , RGB , RGBW
- Control & Dimming:** On/Off, Dali, Push, Triac, 1-10V, Remote, Tunable
- CRI:** Ra≥80, Ra≥90
- Input voltage:** 200-240V AC.

Technical Features & Certifications:

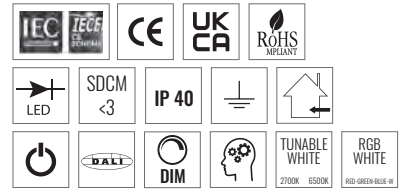

Light Beam

UGR≤19 UGR≤20

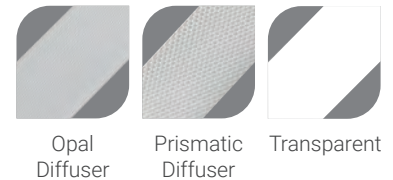
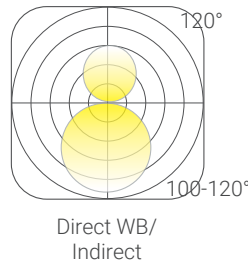

Main Body Colours:

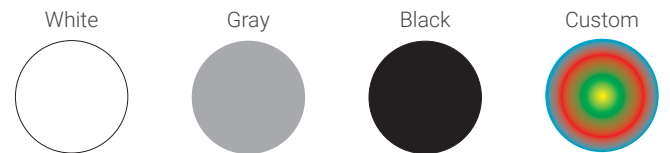

Installation

Surface Mounted

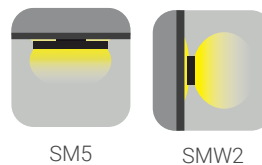

Suspended

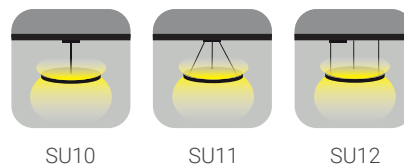

Dimensions

Sections

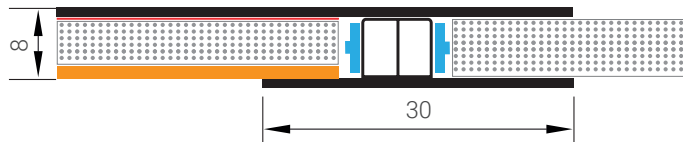
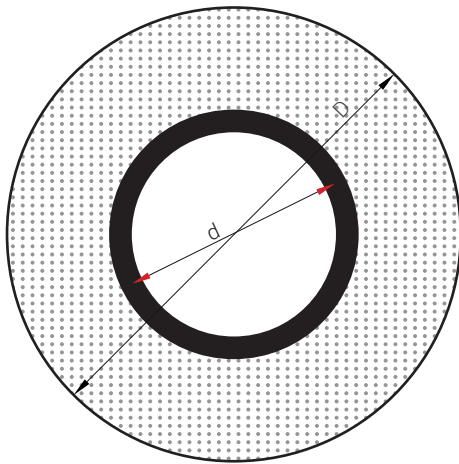

Diameter (Ø) D-d mm		Power W	Lumen lm	Efficiency lm/W
400-200	MP	18	2040	112
	HP	26	2954	112
600-300	MP	27	3060	112
	HP	40	4431	112
900-450	MP	41	4589	112
	HP	59	6647	112
for Opal Diffuser				

Standard Reference Conditions:

Luminous flux values are calculated at 4000K CCT with a system efficacy of 140 lm/W.

Technical values may change depending on the development of LED and equipment. For detailed and accurate lighting values, please visit our website at www.sonled.com

Custom length production is available upon request



PDA SU D2
Panel Light Design Alfa Direct/Indirect
 Suspended



PDB SU D2
Panel Light Design Beta Direct/Indirect
 Suspended

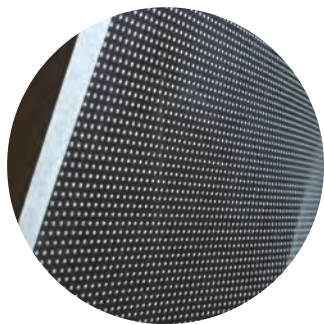

Specifications

- Profile Section:** h11 mm
- Main Body:** Aluminium + Steel Profile with static powder painted, Reflector, Difusser instead of Aluminium sheet for Up lighting.
- Optic Systems:** PMMA Acrylic with galvo laser marking,
- Lighting Direction:** Direct/Indirect (D2)
- Installation:** Suspended (SU)
- Beam angle:** 120°
- Light efficiency:** Avarage 100-120lm/W
- Power:** Medium Power (MP), High Power (LP)
- CCT:** 2400~6500K , RGB , RGBW
- Control & Dimming:** On/Off, Dali, Push, Triac, 1-10V, Remote, Tunable
- CRI:** Ra≥80, Ra≥90
- Input voltage:** 200-240V AC.

Technical Features & Certifications:

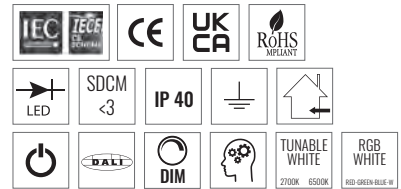

Light Beam

UGR≤19 UGR≤20

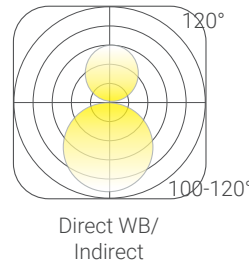

Main Body Colours:

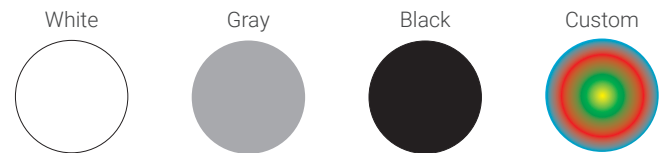

Installation

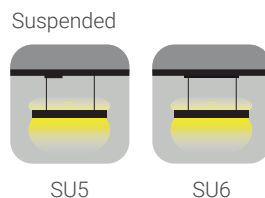

Dimensions

Sections

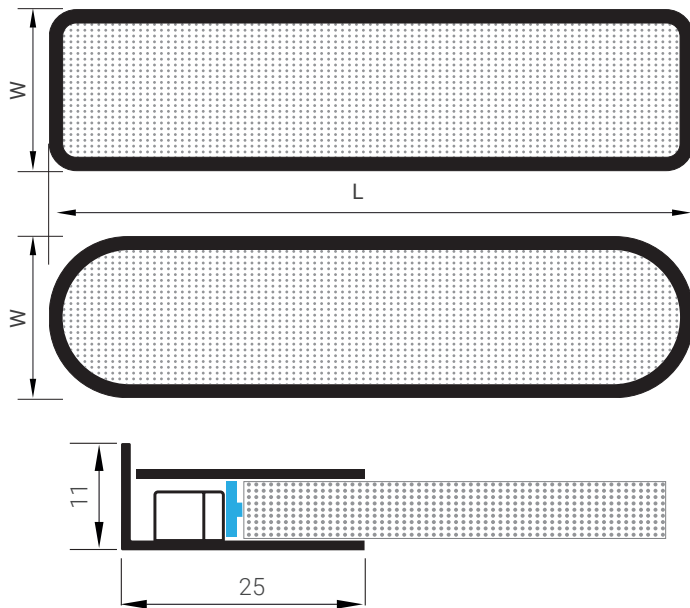

W x L mm		Power W	Lumen lm	Efficiency lm/W
600 x 300	MP	26	3289	126
	HP	38	4763	126
900 x 300	MP	35	4385	126
	HP	50	6350	126
1200 x 300	MP	44	5481	126
	HP	63	7938	126
for Opal Diffuser				

Standard Reference Conditions:

Luminous flux values are calculated at 4000K CCT with a system efficacy of 140 lm/W.

Technical values may change depending on the development of LED and equipment. For detailed and accurate lighting values, please visit our website at www.sonled.com

Custom length production is available upon request



PDD SU D2
Panel Light Design Delta Direct/Indirect
 Suspended



PDG SU D2
Panel Light Design Gama Direct/Indirect
 Suspended

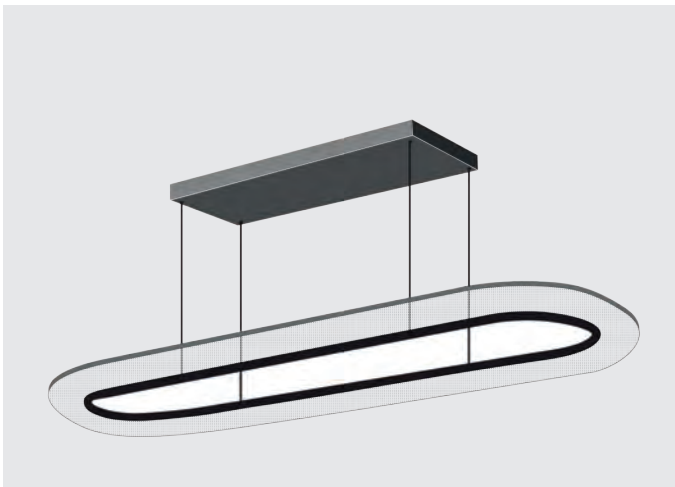

Specifications

- Profile Section:** h11 mm
- Main Body:** Aluminium + Steel Profile with static powder painted, Reflector, Difusser instead of Aluminium sheet for Up lighting.
- Optic Systems:** PMMA Acrylic with galvo laser marking,
- Lighting Direction:** Direct/Indirect (D2)
- Installation:** Suspended (SU)
- Beam angle:** 120°
- Light efficiency:** Avarage 100-120lm/W
- Power:** Medium Power (MP), High Power (LP)
- CCT:** 2400~6500K , RGB , RGBW
- Control & Dimming:** On/Off, Dali, Push, Triac, 1-10V, Remote, Tunable
- CRI:** Ra≥80, Ra≥90
- Input voltage:** 200-240V AC.

Technical Features & Certifications:

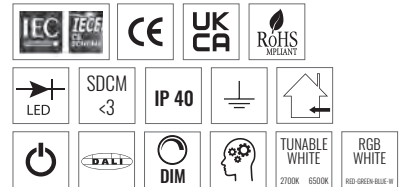

Light Beam

UGR≤19 UGR≤20

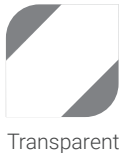
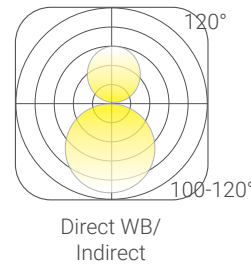

Main Body Colours:

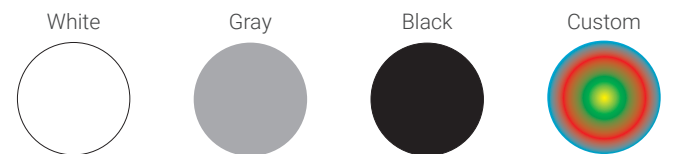

Installation

Suspended



SU5

SU6

Dimensions

Sections

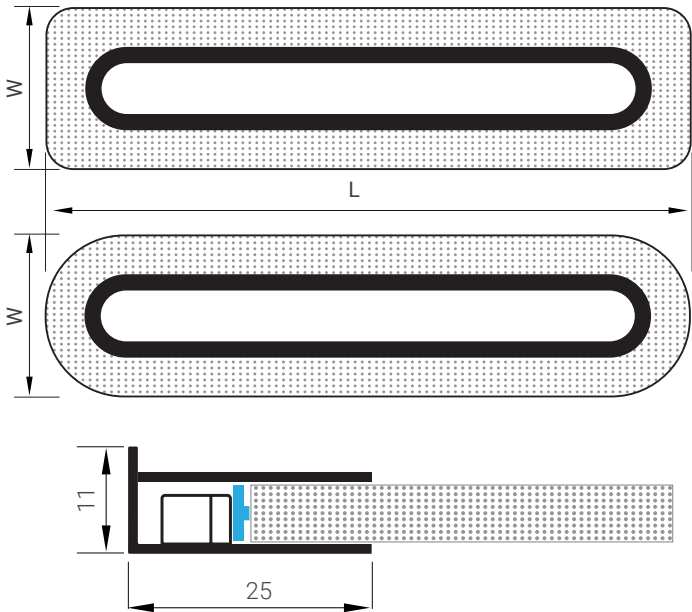

W x L mm		Power W	Lumen lm	Efficiency lm/W
600 x 300	MP	15	1827	126
	HP	21	2646	126
900 x 300	MP	23	2923	126
	HP	34	4234	126
1200 x 300	MP	32	4019	126
	HP	46	5821	126
for Opal Diffuser				

Standard Reference Conditions:

Luminous flux values are calculated at 4000K CCT with a system efficacy of 140 lm/W.

Technical values may change depending on the development of LED and equipment. For detailed and accurate lighting values, please visit our website at www.sonled.com

Custom length production is available upon request



CHANDELIERS





CHANDELIERS

Crafted Light. Engineered Presence.

A chandelier is never just a luminaire.
It is a statement of material, proportion, and atmosphere.

At SONLED, our chandelier collection combines advanced production techniques with architectural intent. Each piece is designed not only to illuminate, but to define space.

Our acrylic chandeliers are shaped through precision thermal forming and processed with galvo-laser detailing. By directing light through the edge of laser-treated acrylic, we create luminous surfaces that appear both structured and weightless. The result is light that feels engraved into the material itself.

For projects requiring stronger sculptural expression, our metal chandeliers are produced using custom spinning molds and specialized forming techniques. These processes allow us to achieve clean geometries, seamless curves, and distinctive architectural silhouettes.

We also integrate acoustic molding technologies into selected models — combining sound absorption and lighting into a single design element. These acoustic lighting chandeliers enhance spatial comfort while maintaining visual impact.

Each chandelier is customizable in size, finish, and configuration, making it suitable for hospitality, retail, residential, and large-scale architectural environments.

Material meets light.
Craft meets engineering.
Form becomes atmosphere.

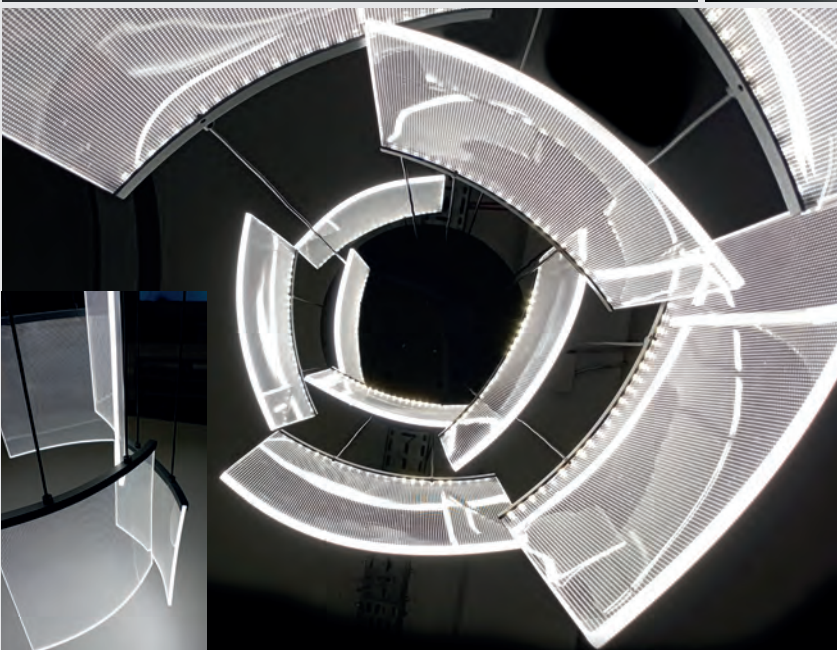

Modern Acrylic Chandeliers (MAC)

Under the Modern Acrylic Chandeliers (MAC) product line, we manage the entire process in an integrated manner—from precision thermoforming of acrylic under controlled heat, to high-accuracy galvo laser marking, and engineered LED edge-lighting that activates the acrylic cross-section to create luminous surfaces—delivering distinctive, fully customized chandelier designs tailored to each project.



MMC-01

D500



MMC-02

D600



MMC-03

D550



MMC-04

D400



MMC-05

D400



D280



MMC-07

D200

D300



MMC-08

D150

D200

D250



MMC-09

D200

D300

D400



MMC-10

D300



MMC-11

D250



MMC-12

D300
D400



MMC-13

D350



MMC-14

D300



MMC-15

D200

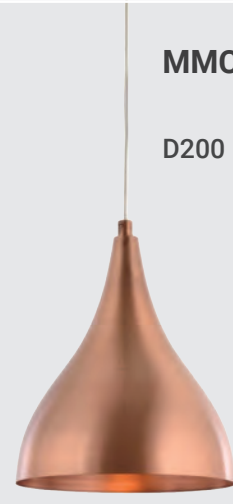

MMC-16

D400



MMC-17

D200
D300



MMC-18

D320
D430





MFC-HEMISPHERE

Outside: Dark Grey
Inside: White
E27 LAMP
(without lamp)

D61 * H35



MFC-SKIRT

Outside: Green
Inside: White
E27 LAMP
(without lamp)

D60 * H40



MFC-DOME

Outside: Dark Grey
Inside: White
E27 LAMP
(without lamp)

D52 * H30



MFC-KUBBE

Outside: Grey
Inside: White
E27 LAMP
(without lamp)

D57 * H40



MFC-FUNNEL

Outside: Grey
Inside: White
E27 LAMP
(without lamp)

D30 * H30



MFC-CONE

Outside: Orange
Inside: White
E27 LAMP
(without lamp)

D31 * H27



MFC-RANGE OF HILLS

Outside: Grey
Inside: White
E27 LAMP
(without lamp)

L121 * W61 * H27



MFC-PYRAMID

Outside: Red
Inside: Light Grey
LED linear 18W

L86 * W39 * H16



MFC-HILLS

Outside: Dark Grey
Inside: Light Grey
7W * 3 HCS
(without lamp)

L59 * W59 * H22



MFC-COVER

Outside: Green
Inside: White
E27 LAMP

D:42 * H16



MFC-STYLE

Outside: Grey
Inside: White
E27 LAMP
(without lamp)

D33 * H6
D46 * H10
D13 * H10
TOTAL H18



MFC-HAT

Outside: Black
Inside: White
E27 LAMP
(without lamp)

D50 * H11



MFC-KEP

Outside: Dark Grey
Inside: White
E27 LAMP
(without lamp)

D44 * H16



MFC-EYE

Outside: Grey
Inside: White
E27 LAMP
(without lamp)

D37 * H19



MFC-DROP

Outside: Dark Grey
Inside: Light Grey
LED COB 5 W

D60
D45



MFC-TRAY Small

Outside: Grey
Inside: Orange
LED COB 5 W

L26 * W26 * H7,5



MFC-TRAY Large

Outside: Dark Grey
Inside: Light Grey
LED COB 5 W

L40 * W31 * H7,5





MFC-SLOTFIT Pumpkin

Outside: Grey
Inside: White
E27 LAMP
(without lamp)

D42 * 21



MFC-SLOTFIT Barrel

Outside: Grey
Inside: White
E27 LAMP
(without lamp)

D29 * 26



MFC-SLOTFIT Garlic

Outside: Grey
Inside: White
E27 LAMP
(without lamp)

D40 * 21



MFC-SLOTFIT Echinus

Outside: Grey
Inside: White
E27 LAMP
(without lamp)

D32 * H18

D49 * H21

D60 * H24



MFC-SLOTFIT Filter

Outside: Grey
Inside: White
E27 LAMP
(without lamp)

D30 * H35



MFC-SLOTFIT YiPeng

Outside: Grey
Inside: White
E27 LAMP
(without lamp)

D25 * H50



MFC-SLOTFIT Carousel

Outside: Grey
Inside: White
E27 LAMP
(without lamp)

D36 * H26

D50 * H38



SonAcoustiq specializes in modern acoustic solutions made from high-quality PET felt. Our product range is designed for architects, interior designers, and project developers who seek premium acoustic performance combined with aesthetic versatility. All products are lightweight, environmentally responsible, highly customizable, and suitable for both commercial and residential spaces.

Premium PET Felt
Architectural & Interior Acoustic Products

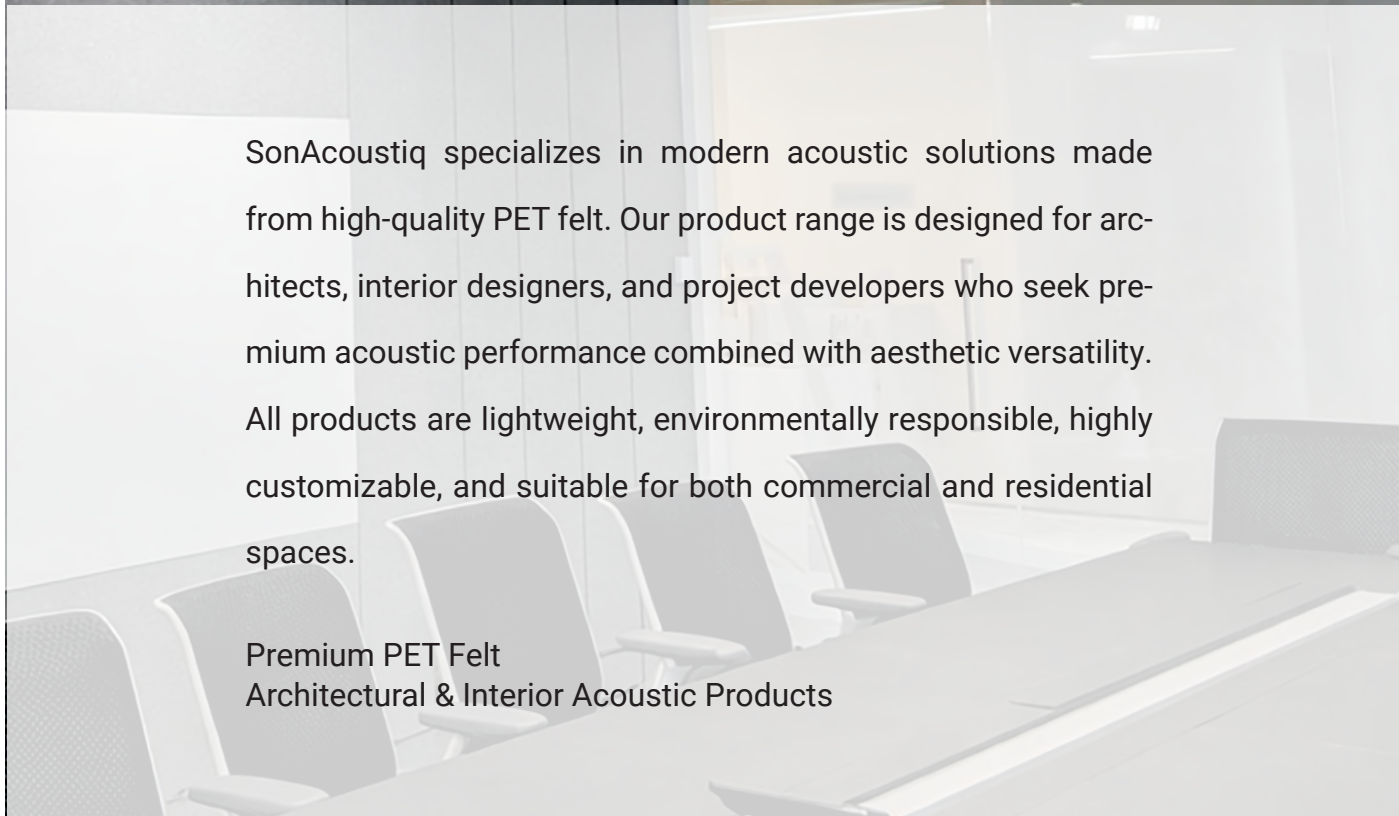

SONACOUSTIQ

Architectural & Interior Acoustic Products Premium PET Felt

Where Sound Becomes Form.

Every space has a sound.

Some echo. Some absorb. Some feel calm the moment you enter.

The SONLED Acoustic collection is designed to shape that invisible layer of architecture — transforming sound control into a visible design language.

Our acoustic panels are not simply applied surfaces; they become part of the spatial composition. Installed on walls, they introduce texture and depth. Suspended as baffles, they define rhythm across ceilings while reducing reverberation. Integrated with our lighting systems, they evolve into luminous forms that balance light and sound in one cohesive structure.

Acoustics is no longer hidden. It is expressed.

By combining PET felt panels with architectural lighting, we create environments that feel composed — visually quiet, acoustically controlled, and materially warm.

And most importantly, we do not limit design to standard formats.

Each project has its own geometry, scale, and acoustic challenge. We produce according to your concept. Whether the need is custom-cut panels, unique ceiling compositions, integrated lighting details, or fully tailored acoustic forms — we work alongside architects and designers to transform ideas into buildable solutions.

You design. We engineer. Together, we shape the atmosphere.



Acoustic Plain PET Felt Panels / BASE MATERIALS

A minimalistic yet highly effective acoustic solution, available in a broad range of colors and thickness options. Plain Panels can be installed on large wall surfaces, ceilings, or custom-designed partitions. Their simple form makes them adaptable to any architectural style, offering clean lines and warm textile acoustics.

TECHNICAL SPECIFICATIONS

COMPOSITION 60% Recycled Polyester (PET) (100% Pes)

DIMENSIONS WIDTH Production is made between 3000mm and 2700mm.

THICKNESS & WEIGHT	1000x2000 mm	1220x2440 mm	1220x3000 mm	1500x3000 mm	2000x3000 mm	2500x3000 mm
6mm (±0.5mm) 1500 g/m ² (±10%)	•	•	•	•	•	•
9mm (±0.5mm) 1500 g/m ² (±10%)	•	•	•	•	•	•
12mm (±0.5mm) 2400 g/m ² (±10%)	•	•	•	•	•	•
15mm (±0.5mm) 2700 g/m ² (±10%)	•	•	•	•	•	
18mm (±0.5mm) 3000 g/m ² (±10%)	•	•	•	•		
20mm (±0.5mm) 3500 g/m ² (±10%)	•	•	•	•		
24mm (±0.5mm) 3700 g/m ² (±10%)	•	•	•	•		

ACOUSTIC NRC:up to 0.20 - 1.00 (subject to mounting conditions)

FIRE TEST STANDARDS EN 1021 - 1 (cigarette)

EN 13501-1 (SBI) Adhered Class B-s1,d0

THERMAL RESISTANCE 0.0331 W/m²K - 0.0446 W/m²K, ISO 110902:2014

LIGHT FASTNESS 4+ (ISO 105 - B02)

ENVIRONMENT Non VOCs emission formaldehyde free and Phenol-free, Oekotex Class 1, Phthalate Free

CLEANNING Vacuum regularly. Professionally dry clean or wipe clean with a dampcloth.

GENERAL Tackable, impact resistant, bacteria resistant, moisture resistant, installation friendly.

PANEL PET FELT COLLECTIONS



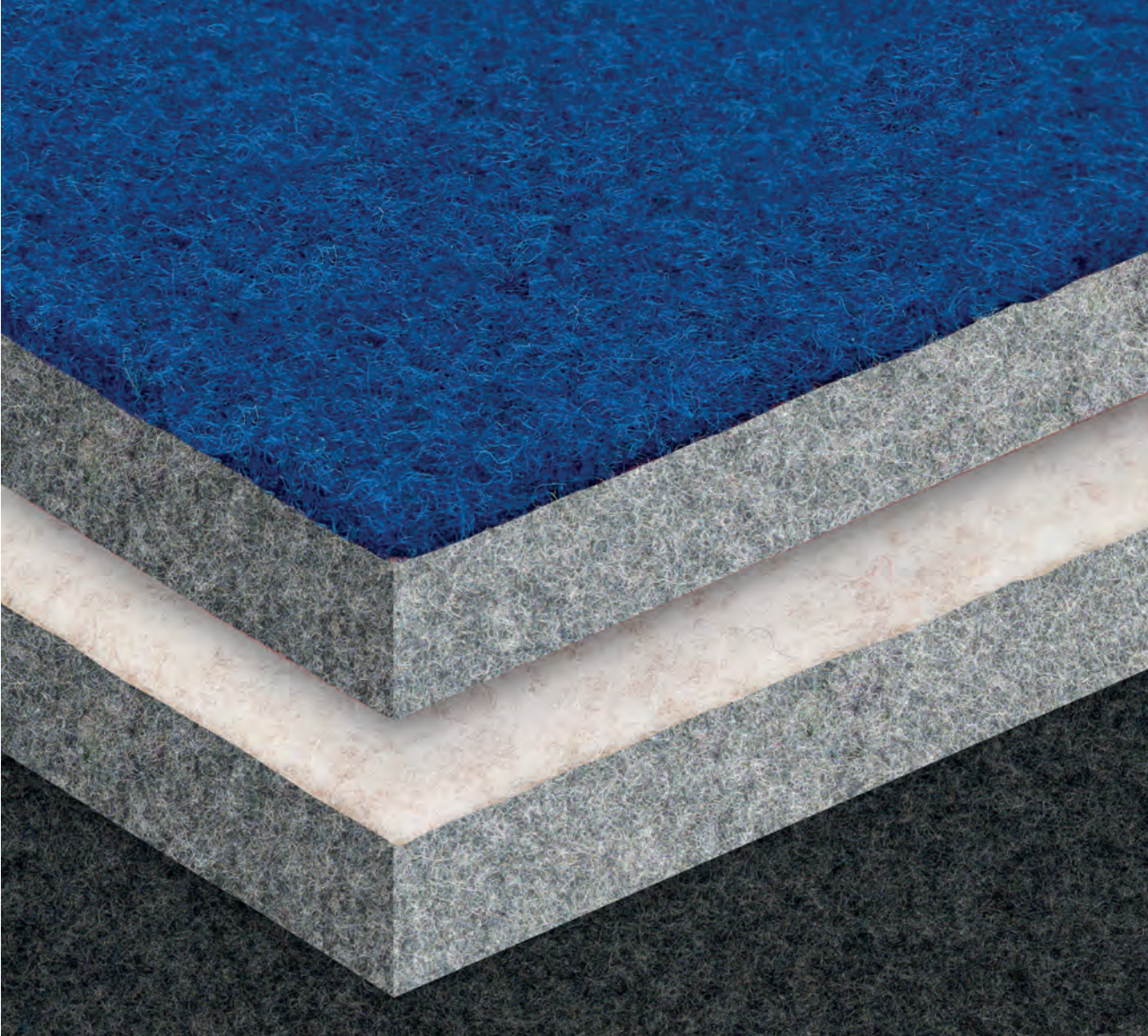

 SA60_Snow	 SA60_Mist	 SA60_Slate	 SA60_Obsidian
 SA60_Dune	 SA60_Clay	 SA60_Sunset	 SA60_Pulse
 SA60_Moss	 SA60_Ocean	 SA60_Graphite	 SA60_Spring
 SA99_Light	 SA99_Stone	 SA99_Smoke	 SA99_Shadow

Felt is produced in special thicknesses and weights (between 400 g/m² and 4000 g/m²). Please contact the production department.

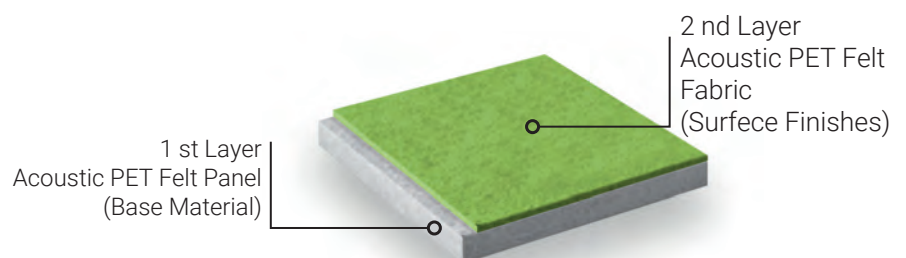

Acoustic Laminated PET Felt Panels / SURFACE FINISHES

Multi Panel features a curated selection of stylish patterns applied to a second layer of PET Felt Panel, adding a touch of elegance and elevated acoustic performance. By combining depth, dimension, and color, Multi Panel delivers both visual impact and premium sound absorption. Versatile and refined, it seamlessly complements any color palette or interior style-making it an ideal choice for sophisticated, acoustically conscious spaces.



Premium PET Felt
Architectural & Interior Acoustic Products

TECHNICAL SPECIFICATIONS

COMPOSITION 60% Recycled Ptolyster (PET) (100% Pes)

DIMENSIONS WIDTH Max. Width: 1500mm - 2500mm (+/- 3mm)

THICKNESS & WEIGHT	1000x2000 mm	1220x2440 mm	1220x3000 mm	1500x3000 mm	2000x3000 mm	2500x3000 mm
6mm (±0.5mm) 1500 g/m ² (±10%)	•	•	•	•	•	•
9mm (±0.5mm) 1500 g/m ² (±10%)	•	•	•	•	•	•
12mm (±0.5mm) 2400 g/m ² (±10%)	•	•	•	•	•	•
15mm (±0.5mm) 2700 g/m ² (±10%)	•	•	•	•	•	
18mm (±0.5mm) 3000 g/m ² (±10%)	•	•	•	•		
20mm (±0.5mm) 3500 g/m ² (±10%)	•	•	•	•		
24mm (±0.5mm) 3700 g/m ² (±10%)	•	•	•	•		

ACOUSTIC NRC:up to 0.20 - 1.00 (subject to mounting conditions)

FIRE TEST STANDARDS EN 1021 - 1 (cigarette), EN 13501-1 (SBI) Adhered Class B-s1,d0

THERMAL RESISTANCE 0.0331 W/m²K - 0.0446 W/m²K, ISO 110902:2014

LIGHT FASTNESS 4+ (ISO 105 - B02)

ENVIRONMENT Non VOCs emission formaldehyde free and Phenol-free, Oekotex Class 1, Phthalate Free

GENERAL Tackable, impact resistant, bacteria resistant, moisture resistant, installation friendly.

FLAT PET FELT COLLECTIONS



SA_D-001



SA_D-002



SA_D-003



SA_D-004



SA_D-005



SA_D-006



SA_D-007



SA_D-008



SA_D-009



SA_D-010



SA_D-011



SA_D-012



SA_D-013



SA_D-014



SA_D-015



SA_D-016



SA_D-017



SA_D-018



SA_D-019



SA_D-020





LIGHTING DESIGN & TECHNOLOGY GUIDE

Lighting cannot be defined by a single parameter. Light quality, optical control, electronic infrastructure, human perception, and system integration must be evaluated as a connected whole.

This guide presents a structured technical framework covering the fundamental principles of professional lighting design – from visual comfort and light physics to LED technologies, human-centric approaches, and integrated acoustic and control systems.

Each section builds upon the previous one, forming a clear and systematic reference for architects, lighting designers, and technical professionals.

GUIDE STRUCTURE

A. LIGHT QUALITY & VISUAL COMFORT

CCT · CRI · UGR

B. TECHNICAL CHARACTERISTICS OF LIGHT

Lumen · Lux · Candela · Optics · Beam Angle · Acrylic & Light Interaction

C. LED SOURCE & ELECTRONICS

LED Technologies · MacAdam / SDCM · LED Drivers & Control Infrastructure

D. VISUAL COMFORT, HEALTH & PERFORMANCE

Flicker · Human Centric Lighting · Circadian-Oriented Lighting Design

E. ACOUSTIC & LIGHTING INTEGRATION

F. SMART & FUTURE-ORIENTED LIGHTING

Lighting Control Protocols · Energy Efficiency · Sustainability

DISCOVERY

Understanding Light Beyond Lumens



A. LIGHT QUALITY & VISUAL COMFORT

COLOR TEMPERATURE (CCT)

Color Temperature (CCT) is a parameter that defines the chromatic appearance of a light source, referenced to the color of light emitted by a black body radiator at a given temperature. It is measured in Kelvin (K) and determines whether the light is perceived as “warm” or “cool.”

CCT describes the **color tone** of a light source; however, it does not provide information about color accuracy or color fidelity on its own.

Typical CCT Ranges and Applications

- 2700K – 3000K**
 Warm white light. Due to its low blue content, it is commonly preferred for residential, hospitality, restaurant, and relaxation areas.
- 3500K – 4000K**
 Neutral white light. Provides a balance between visual comfort and perceptual clarity. Widely used in offices, retail spaces, and educational facilities.
- 5000K – 6500K**
 Cool white light. Enhances contrast perception and is typically applied in industrial environments, laboratories, and healthcare facilities.

Technical Notes

- Different LED light sources with the same CCT value may produce **different visual impressions** due to variations in their spectral power distribution (SPD).
- CCT should be evaluated in conjunction with **CRI, TM-30, and MacAdam (SDCM)** values.
- In adjacent luminaires, control of CCT tolerance is critical to maintain visual consistency.

An incorrect CCT selection may negatively affect spatial perception, user comfort, and functional performance. In architectural and professional lighting projects, CCT selection should be based on **space function, user profile, and visual tasks**.

CCT, expressed in Kelvin (K), defines the perceived color appearance of light.

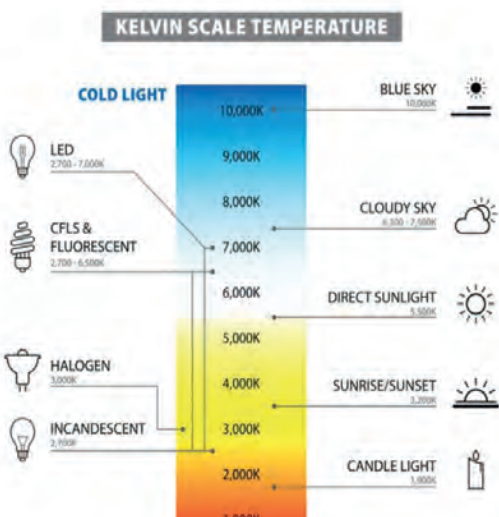

CRI – COLOR RENDERING INDEX

CRI (Color Rendering Index) is a metric that describes how accurately a light source renders the colors of objects compared to a reference light source (daylight or a black body radiator). The CRI scale ranges from **0 to 100**, where **100** represents perfect color rendering.

CRI is calculated according to the **CIE Ra** method, based on eight standardized color samples (R1–R8).

CRI Classification

1. CRI ≥ 80

Acceptable level for general commercial and industrial applications.

2. CRI ≥ 90

High color fidelity for architectural lighting, retail, offices, and educational environments.

3. CRI ≥ 95

Required for museums, art galleries, healthcare facilities, and color-critical applications.

4. CRI evaluates **color fidelity only**; it does not describe color saturation or vividness.

5. Light sources with identical CRI values may produce **different visual impressions** due to differences in spectral power distribution (SPD).

6. In contemporary lighting design, CRI should be assessed alongside **TM-30 (Rf / Rg)** metrics.

Insufficient CRI performance may result in inaccurate color perception of materials and surfaces, particularly in architectural and retail environments. In professional lighting projects, CRI must be evaluated together with **CCT and MacAdam (SDCM)** values.



UGR – UNIFIED GLARE RATING

UGR (Unified Glare Rating) is a standardized metric used to evaluate **discomfort glare** in interior lighting applications. It quantifies how disturbing a lighting installation is perceived by occupants.

The UGR value is calculated based on **luminaire luminance, position relative to the observer, background luminance, and room geometry**.

Lower UGR values indicate reduced glare and improved visual comfort.

Typical UGR Classification

UGR < 16

Areas requiring very high visual comfort (executive offices, design studios)

UGR < 19

Offices, educational facilities, computer-based workspaces
(Compliant with EN 12464-1)

UGR < 22

General interior spaces and circulation areas

UGR ≥ 25

High glare – not recommended for visual comfort

Technical Notes

UGR is **not an inherent fixed property of a luminaire**; it depends on installation height, layout, and surface reflectance values (ρ).

The same luminaire may result in **different UGR values** across different projects.

Low UGR performance is typically achieved through **advanced optical design, microprismatic diffusers, and controlled light distribution**.

Excessive glare can lead to eye strain, reduced concentration, and user discomfort. In professional lighting design, UGR is as critical as illuminance levels and must always be evaluated **on a project-specific basis**.

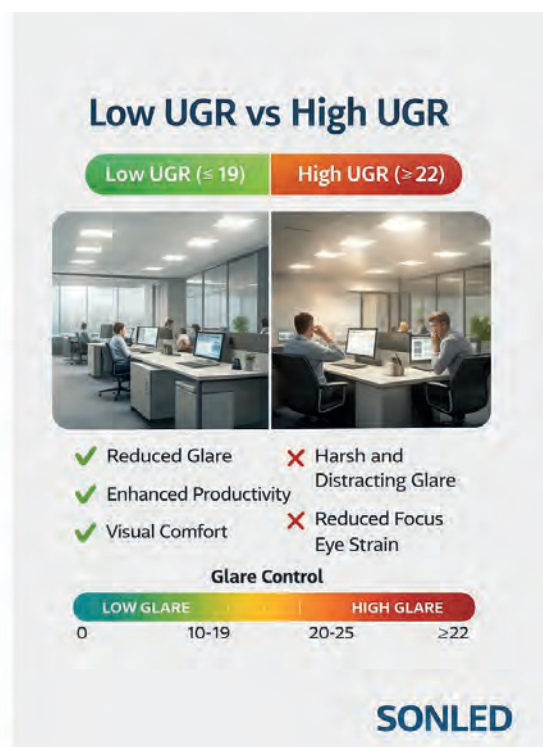
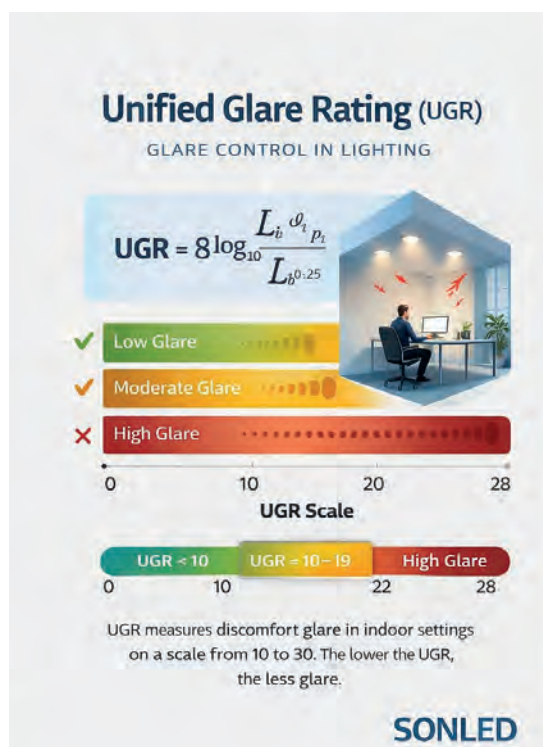

B- TECHNICAL CHARACTERISTICS OF LIGHT

LUMINOUS FLUX (LUMEN), ILLUMINANCE (LUX) AND LUMINOUS INTENSITY (CANDELA)

- **Lumen (lm):** Total luminous flux emitted by a light source; indicates how much light is produced.
- **Lux (lx):** Illuminance on a surface ($1 \text{ lx} = 1 \text{ lm/m}^2$); defines application performance.
- **Candela (cd):** Luminous intensity in a given direction; critical for optical control and accent lighting.

Technical Notes

- Two luminaires with identical lumen output may deliver very different lux levels depending on optics.
- Candela distribution is directly related to beam angle and lens design.

OPTICS & LENS TECHNOLOGIES - Shaping Light

Optical systems control, shape, and distribute light emitted from LEDs. Proper optical design determines UGR, efficiency, uniformity, and accent performance.

- **Reflect Lens (Reflector-Based):**
Directs light via reflective surfaces; high efficiency and controlled distribution.
- **Optic Lens (TIR / PMMA):**
Refracts and collects light for precise narrow-to-wide beam control.
- **Diffusers (Opal / Microprismatic):**
Improve uniformity and reduce glare; enhance UGR performance.

BEAM ANGLE & LIGHT DISTRIBUTION

Beam Angle is defined by the angle at which light intensity

falls to half its maximum value, determining whether lighting is accent or general.

- **Narrow (10°–30°):** High candela, strong accent, increased glare risk.
- **Accent and architectural details**
- **Medium (36°–60°):** Functional lighting with balanced distribution
- **Wide (90°+):** General illumination and uniform coverage

Technical Note:

Beam selection must be evaluated together with mounting height, distance, and target surface.

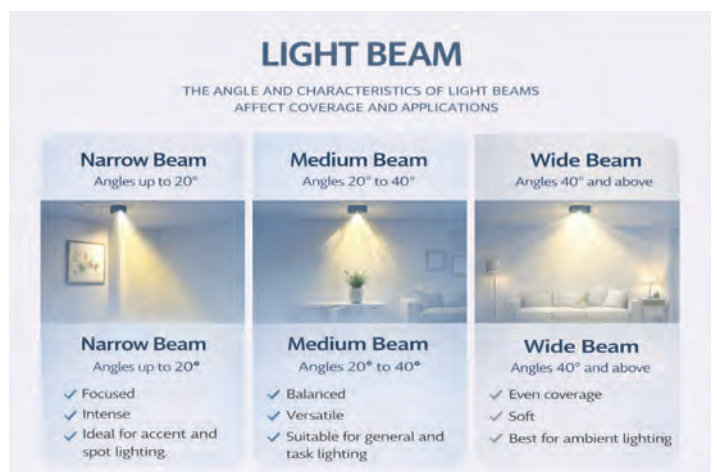

ACRYLIC & LIGHT INTERACTION

Acrylic (PMMA) is not merely an aesthetic surface in architectural lighting; it is a controlled optical medium through which light is guided, shaped, and revealed. Thanks to its high transmittance and homogeneous structure, acrylic plays a key role in edge-lit lighting systems.

• OPTICAL PROPERTIES OF ACRYLIC

- Light transmittance above 90%
- Homogeneous molecular structure
- Low internal scattering
- Controlled refractive index

These properties allow light emitted by LEDs to travel efficiently within the acrylic material.

• EDGE-LIT ILLUMINATION PRINCIPLE

In edge-lit systems, light is injected through the edge surface of the acrylic panel. Inside the material, light propagates via Total Internal Reflection (TIR).

This results in:

- Concealed light sources
- Minimal glare
- Soft and uniform surface illumination



• GALVO LASER MARKING & LIGHT EXTRACTION

Galvo laser engraving introduces micro-scale patterns that intentionally disrupt internal reflection.

These markings:

- Extract light at predefined locations
- Create textures, patterns, or graphics
- Generate the perception of light flowing across the surface

Laser marking is therefore an optical design tool rather than a decorative process.

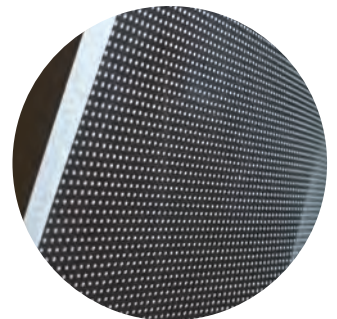

- DEPTH, PATTERN & LIGHT PERCEPTION

The density, depth, and orientation of laser patterns directly determine how light exits the acrylic.

As a result:

- Light appears layered and dimensional
- The luminaire becomes a visual object
- The lighting element integrates seamlessly with architecture

• ADVANTAGES OF ACRYLIC LIGHTING SYSTEMS

- Low glare performance
- Slim and lightweight structures
- Concealed, indirect lighting effect
- High design flexibility
- Compatibility with architectural and decorative applications



C. LED SOURCE & ELECTRONICS

1. LED SOURCE TECHNOLOGIES

In LED technologies, color consistency is critical for professional applications.

MacAdam / SDCM defines the perceptible color difference between LEDs.

- 2 SDCM: Premium architectural applications
- 3 SDCM: Professional standard
- 5+ SDCM: Color difference becomes noticeable

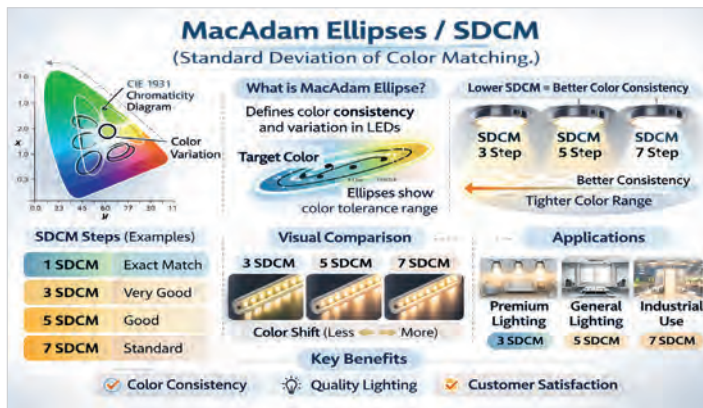

LED Types (Examples):

- Mid-Power LEDs: High efficacy, broad applications
- High-Power LEDs: High intensity output
- COB LEDs: Uniform surface emission



2. LED DRIVERS & CONTROL INFRASTRUCTURE

LED drivers define how an LED operates, behaves, and performs over time.

Key aspects such as flicker level, dimming behavior, color stability, and lifetime are directly determined by the driver design.

- FLICKER & DRIVER DESIGN

Flicker is rarely caused by the LED itself; it is primarily a driver-related issue.

- Poor driver design : high flicker
- High-frequency, filtered drivers : flicker-free performance

Flicker-free drivers are essential for:

- Visual comfort
- Human-centric lighting
- Circadian-oriented systems

- DRIVER – LED – OPTICS INTERACTION

The driver directly influences:

● LED operating point

- Optical output behavior
- Light quality during dimming

Driver selection must therefore be considered as part of the entire lighting system.

- DIMMING TECHNOLOGIES

- PWM – Pulse Width Modulation
- CCR – Constant Current Reduction
- Hybrid Dimming (PWM + CCR)

Hybrid dimming offers:

- Wide dimming range
- Reduced flicker risk
- Improved color stability



D - VISUAL COMFORT, HEALTH & PERFORMANCE

Lighting performance reaches its true value when it is evaluated through human experience.

Beyond technical parameters, light influences visual comfort, biological rhythms, concentration, and overall well-being. Flicker behavior, spectral composition, and dynamic light scenarios play a decisive role in how users perceive and interact with a space over time.

This section focuses on the human-centric outcomes of lighting design, translating technical decisions into comfort, health, and performance.

FLICKER (TEMPORAL LIGHT MODULATION)

Flicker refers to periodic variations in light output over time. In LED systems, flicker is strongly influenced by driver quality and control methods.

Flicker may cause eye strain, headaches, reduced concentration, and health issues for sensitive users.

Key Parameters:

- Flicker Percentage (%)
- Flicker Index
- Temporal Light Artifacts (TLA)

Technical Notes

- Low-frequency flicker (<100 Hz) can be perceived by the human eye.
- High-quality constant current drivers significantly reduce flicker.
- Dimming methods (especially PWM) may increase flicker risk.



HUMAN CENTRIC LIGHTING (HCL)

Circadian-Oriented Lighting Design

Human Centric Lighting (HCL) is a lighting design approach that considers the impact of light on the human circadian rhythm.

Light directly influences melatonin production, alertness, and overall well-being.

HCL systems typically include:

- Dynamic CCT tuning
- Time-based lighting scenarios
- Daylight integration
- Blue spectral content ($\approx 480 \text{ nm}$) is critical for biological impact.
- HCL focuses on biological effectiveness, not only visual performance.
- Widely applied in offices, education, and healthcare facilities.



TECHNICAL ELEMENTS OF VISUAL COMFORT

Visual comfort is achieved through the balanced integration of:

1. low glare (UGR control)
2. flicker-free drivers
3. appropriate CCT selection
4. high color rendering



E. ACOUSTIC & LIGHTING INTEGRATION

In contemporary interior design, spatial comfort is defined not only by what we see, but also by what we hear.

Lighting and acoustics are two inseparable components of the same experience. While light shapes visual perception, sound behavior defines how a space feels and functions. Integrated acoustic lighting systems address both parameters simultaneously, offering a holistic solution for modern interiors.

This section explores how light emission and sound absorption can be combined within a single system to enhance visual clarity, acoustic comfort, and architectural coherence.

Acoustic lighting systems combine visual and acoustic comfort within a single solution. They are especially effective in open offices and large-volume spaces where reverberation control is required.

These systems evaluate:

- Sound absorption coefficient (NRC / α_w)
- Light distribution and UGR
- Spatial integration

Technical Notes

- Acoustic panels absorb mid-to-high frequency sound waves.
- Lighting performance is optimized through panel geometry and optical design.
- Provides architectural integration with functional efficiency.



- SOUND BEHAVIOR IN SPACE

Sound waves in enclosed spaces:

- reflect,
- refract,
- overlap,
- create reverberation.

Uncontrolled surfaces allow sound energy to persist, reducing speech clarity and increasing fatigue.

Acoustic lighting absorbs sound close to the source, reducing reverberation time.

- NRC – NOISE REDUCTION COEFFICIENT

NRC defines how much sound energy a material absorbs.

- 0.30–0.50 → limited absorption
- 0.60–0.75 → good performance
- 0.80–1.00 → high absorption

Acoustic lighting aims to achieve high NRC values without compromising lighting quality.

- RT60 – REVERBERATION TIME

RT60 measures the time required for sound to decay by 60 dB.

- Long RT60 → echoic, tiring environments
- Short RT60 → controlled, intelligible spaces

Ceiling-mounted acoustic lighting operates in the most effective acoustic zone.

- ACOUSTIC MATERIAL STRUCTURE

Typical materials include:

- fiberglass cores,
- recycled PET felt,
- micro-porous composites.

These structures target mid-to-high frequencies, especially human speech ranges, while remaining compatible with optical systems.

- LIGHT & ACOUSTIC PERFORMANCE INTERACTION

Acoustic performance and lighting performance are interdependent.

- Surface texture affects light diffusion
- Optics are adapted to panel geometry
- Glare control is achieved through combined design

Acoustic lighting is therefore a single engineered solution, not a hybrid of two separate products.

- APPLICATION SCENARIOS

• Open Offices

• $NRC \geq 0.75$

• Reduced RT60

• $UGR < 19$

Meeting & Training Spaces

• Enhanced speech intelligibility

• Controlled reverberation

Lobbies & Public Areas

• Acoustic control with architectural impact



F- SMART & FUTURE-ORIENTED LIGHTING

Modern lighting systems extend beyond static illumination.

They are dynamic, connected, and responsive to users, spaces, and time.

Smart lighting integrates control protocols, sensors, and digital interfaces to optimize energy efficiency, user comfort, and system flexibility. From simple dimming scenarios to fully automated building management systems, lighting becomes an adaptive component of the built environment.

This section introduces smart lighting concepts, control protocols, and future-oriented approaches that enable scalable, efficient, and intelligent lighting solutions



1. SMART LIGHTING

Smart Lighting refers to lighting systems that are dynamically, automatically, and remotely controlled through sensors, control protocols, and software. The objective is to achieve energy efficiency, user comfort, and operational flexibility.

Smart lighting systems may respond to:

- Daylight levels
- Occupancy / motion detection
- Time schedules
- User-defined scenarios

Technical Notes

- Smart Lighting goes beyond dimming; it is based on scenarios, data, and automation.
- Can be integrated with Building Management Systems (BMS).
- Hardware (luminaires + drivers) and software must be evaluated as a system.

2. LIGHTING CONTROL PROTOCOLS

The main lighting control protocols are as follows, LIGHTING CONTROL PROTOCOLS:

Wired Control Protocols:

DALI (Digital Addressable Lighting Interface)
 DALI-2
 KNX
 DMX512 / RDM
 0–10V (Analog Dimming)
 1–10V (Analog Dimming)
 Phase Cut / TRIAC (Leading / Trailing Edge)
 PWM Dimming
 Push-DIM / SwitchDIM
 Digital Input (Dry Contact)
 Relay On/Off

Wireless Control Protocols:

Casambi (Bluetooth Low Energy)
 Zigbee
 Bluetooth Mesh
 Thread
 Wi-Fi
 EnOcean
 RF Remote (2.4 GHz / Sub-GHz)
 Infrared (IR) Remote

Building / IoT & Integration

BACnet (BMS Integration)

Modbus

MQTT (IoT altyapıları)

API / Cloud Integration (platforma bağlı)

Control Features

On/Off

Dimming

Tunable White (CCT Control)

RGB / RGBW / RGB CCT

Scene Control

Sensor Control (occupancy / daylight harvesting)

Emergency Lighting Interface



3. ENERGY EFFICIENCY & SUSTAINABLE LIGHTING

Energy-efficient lighting aims to deliver the same illuminance with lower energy consumption, while sustainability addresses the environmental impact throughout the product lifecycle.

Key parameters include:

- Luminous efficacy (lm/W)
- Long lifetime (L80 / B10, L90 / B10)
- Smart control integration
- Recyclable materials

Technical Notes

- High lm/W alone is not sufficient; optics and control systems must also be considered.
- Smart controls are among the most effective contributors to energy savings

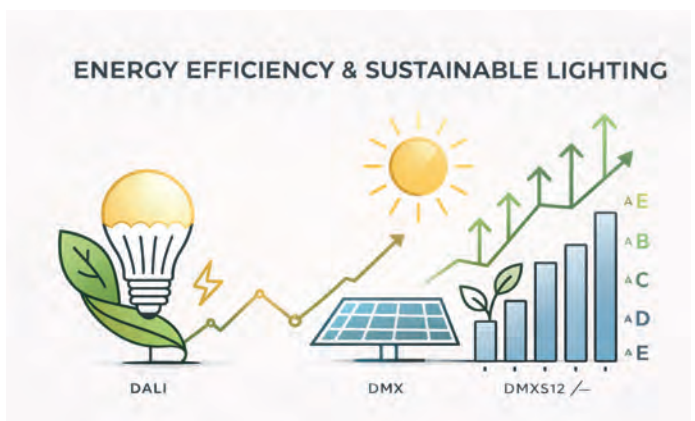

Light Beam

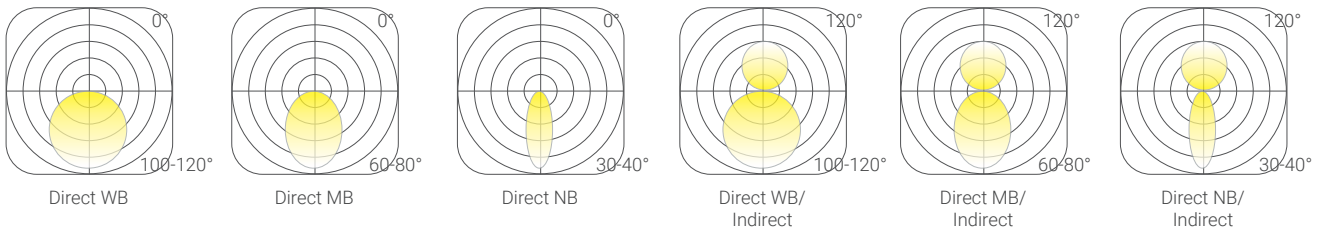

Optic Systems

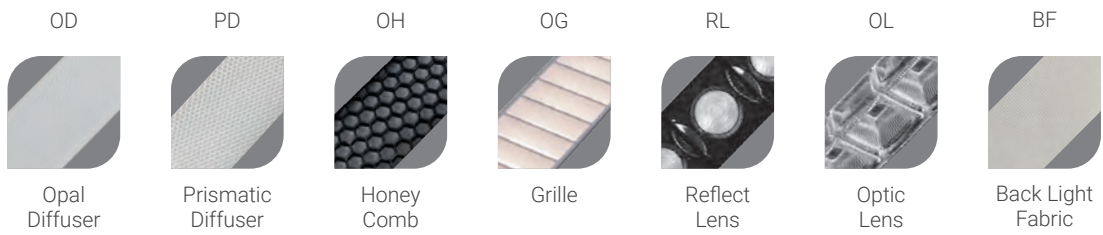

Installation

Recessed



RC

Surface Mounted



SM1 SM2 SM3 SM4 SM5 SMR



SMW SMW2 SMW3 SMW

Suspended

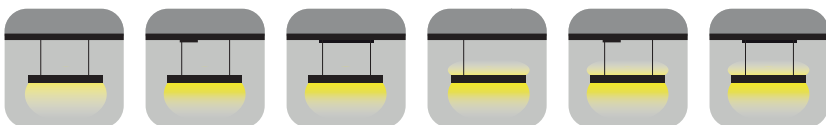

SU1 SU2 SU3 SU4 SU5 SU6

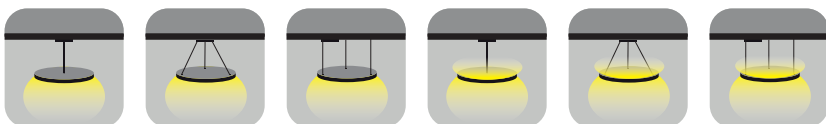

SU7 SU8 SU9 SU10 SU11 SU12

CERTIFICATIONS & GLOBAL COMPLIANCE

PRODUCT CERTIFICATION



CB Scheme
International Electrical Safety Certification



IECEE CB Scheme
International IEC-Based Certification



CE
Compliance with EU Directives



UKCA
UK Conformity Assessed



RoHS
Restriction of Hazardous Substances

LUMINAIRE SAFETY STANDARDS



EN 60598-1
Luminaires – Part 1: General Requirements and Tests



EN 60598-2-1
Fixed Luminaires



EN 60598-2-2
Recessed Luminaires

MANAGEMENT SYSTEMS



ISO 9001:2015

Quality Management System



ISO 14001:2015

Environmental Management Systems



ISO 45001:2018

Occupational Health and Safety Management Systems

SONLED



Son Led Sanayi Ticaret AS
Ikitelli OSB Cevre Sanayi Sitesi 8. Blok No:8.10.12
34490 Basaksehir - Istanbul - Türkiye
Office Line +90 212 486 20 44
Mobile & WhatsApp +90 541 479 54 90
www.sonled.com info@sonled.com